

Total No. of Printed Pages:01

SUBJECT CODE NO:- H-1433
FACULTY OF SCIENCE AND TECHNOLOGY
T.Y.B.Tech.(Electrical) (Sem-V)
Elective-II Special Purpose Electrical Machines
[Revised]

[Time: TWO Hours]

[Max.Marks:40]

Please check whether you have got the right question paper.

N.B

- 1) Question no 1 from section A and Question no 4 from section B is compulsory.
- 2) Solve any one from remaining questions from each section.
- 3) Assume suitable data, if required.

SECTION "A"Q.1 Attempt any five of the following 10

- 1) State the principle of switched reluctance motor.
- 2) What is meant by eddy current?
- 3) Draw the torque speed characteristics of induction two phase servo motor.
- 4) What are the various stator current modes used in synchronous reluctance motor?
- 5) Compare dc and ac servo.
- 6) State the operations of eddy current coupling.

Q.2 a) Explain operation of reluctance motor. 05**OR**b) Explain any one method of control of dc servo motor. 05Q.3 a) Explain operation of dynamometer. 05**OR**b) Explain production of torque of dc servo motor. 05**SECTION "B"**Q.4 Attempt any five of the following: 10

- 1) What is AC tachogenerator?
- 2) State the advantages of induction tachogenerator.
- 3) What does mean by non linearities?
- 4) What is linear motor?
- 5) Draw the dynamic characteristics of AC tachogenerator.
- 6) State the applications of linear motor.

Q.5 a) Explain the reasons for deviations from desired characteristics of induction tachogenerator. 05**OR**b) Explain constructional features of synchros. 05Q.6 a) Explain the principle and working of synchrotransformer. 05**OR**b) Explain the two dimensional field pattern of linear induction motor. 05

Total No. of Printed Pages:1

SUBJECT CODE NO:- H-1434
FACULTY OF SCIENCE AND TECHNOLOGY
T.Y.B.Tech.(Electrical) (Sem-V)
Elective-II Renewable Energy Sources
(Revised)

[Time: Two Hours]**[Max.Marks:40]**

- N.B
- Please check whether you have got the right question paper.
- Question no.1 from section A and Question no 4 from section B is compulsory.
 - Solve any one from remaining questions from each section
 - Assume suitable data, if required.

Section A

- Q.1 Answer any five of the following: 10
- a) Define Solar collectors.
 - b) Define Solar panels.
 - c) List out the various instruments for measuring solar energy.
 - d) Explain the Solar irradiation
 - e) Explain any energy storage system.
 - f) Draw a solar cooling system and label all parts neatly.
 - g) Draw a solar cell and label all parts neatly.
- Q.2 A) Explain Photovoltaic effect. 05
 B) How solar energy is used for room heating. Explain with neat diagram. 05
- Q.3 A) Explain Horizontal axis wind turbine in detail. 05
 B) Explain how we measure solar energy using pyrheliometer with neat diagram. 05

Section B

- Q.4 Answer any five of the following: 10
- a) Explain the term biogas.
 - b) Draw a neat diagram of biogas plant.
 - c) Explain Fermentation
 - d) What do you mean by Tide & Wave
 - e) Draw a neat diagram of energy generation for geothermal sources.
 - f) List the factors controlling yield of biogas.
 - g) List out the advantages of OTEC system.
- Q.5 A) Explain in detail any one type of biogas plant. 05
 B) Explain pyrolysis process in detail. 05
- Q.6 A) Explain wave energy conversion system. 05
 B) Explain energy generation from geothermal sources. 05

Total No. of Printed Pages:01

SUBJECT CODE NO:- H-1435
FACULTY OF SCIENCE AND TECHNOLOGY
T.Y.B.Tech.(Electrical) (Sem-V)
Elective-II Electronic Instrumentation
[Revised]

[Time: TWO Hours]

[Max.Marks:40]

Please check whether you have got the right question paper.

N.B

- 1) Q.1 from section A & Q.5 from section B are compulsory. Attempt any two from the remaining questions in each section.
- 2) Figures to the right hand side indicated full marks.

Section A

- | | | |
|-----|---|----|
| Q.1 | Attempt any four (04) of the following. | 08 |
| | <ol style="list-style-type: none"> a. What are X amplifiers? b. Give the applications of digital storage CRO c. State the functionalities that are available on digital voltmeter. d. What is a dual trace CRO? e. What do you mean by triggering of oscilloscope? | |
| Q.2 | With a neat block diagram explain the modern oscilloscope | 06 |
| Q.3 | What is sampling oscilloscope and give its applications | 06 |
| Q.4 | What is a Q meter explain the construction details of the same | 06 |

Section B

- | | | |
|-----|---|----|
| Q.5 | Attempt any four (04) of the following | 08 |
| | <ol style="list-style-type: none"> a. Compare Led and LCD displays. b. Define the Hall effect c. What are harmonica analysers? d. List the transducer for temperature measurement. e. Status standard signal generators. | |
| Q.6 | With neat diagram explain the resistance and capacitive type of transducer. | 06 |
| Q.7 | Explain the heterodyne wave analyser. | 06 |
| Q.8 | Write a short note on X-Y recorder. | 06 |

SUBJECT CODE NO:- H-1442
FACULTY OF SCIENCE AND TECHNOLOGY
T.Y. B.Tech. (Electrical) (Sem-VI)
Power System Analysis
[REV]

[Time: Three Hours]

[Max. Marks:80]

Please check whether you have got the right question paper.

N.B.:

- Question no 1 from section A and Question no 6 from section B is compulsory.
- Solve any two from remaining questions from each section.
- Assume suitable data, if required.

Section – A

Q.1 Attempt any five of the following: 10

- a. Short note on per unit system.
- b. Explain in brief one-line diagram and impedance diagram.
- c. Explain in brief transient on transmission line.
- d. Short note Z-bus formulation.
- e. What is different between symmetrical and unsymmetrical fault.
- f. Express the per unit impedance Z_{pu} and per unit admittance Y_{pu} of system in term of the base voltage V_{base} and the base volt-amperes $(VA)_{base}$

Q.2 a) Figure shows the schematic diagram of a radial transmission system. The rating and 08

reactance of the various components are shown therein. A load of 60 MW at 0.9 power factor lagging is tapped from the 66 kV substations which is to be maintained at 60 kV. Calculate the terminal voltage of the synchronous machine. Represent the transmission line and the transformer by series only.

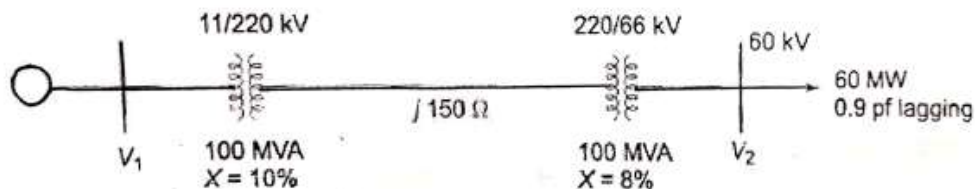

b) Explain in detail representation of transformer. 07

Q.3 a) Three phase short circuit fault occurs at point F in the system shown in figure. 08

Calculate the fault current.

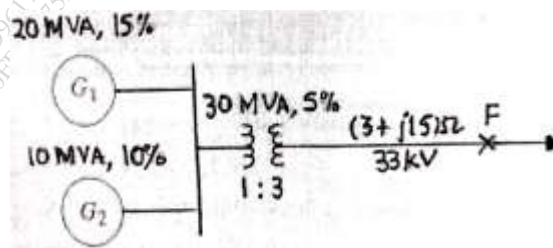

- b) Explain short circuit on loaded synchronous machine. 07
- Q.4 a) Explain characteristic of modern power system and physical structure. 08
 b) Explain selection check list for circuit breaker. 07
- Q.5 a) Rating: 2 MVA, 6.6 kV, $X_1=10\%$ $X_2=7\%$ $X_0=3\%$, $T_1, T_2: 6.6/11$ kV, 2MVA, $X=5\%$ 08
 $X_{1line}=X_{2line}=j0.5 \Omega$. $X_{0line}=1.5 \Omega$. Fault occurs at point F as shown figure draw sequence networks; assume initially system is on no load.

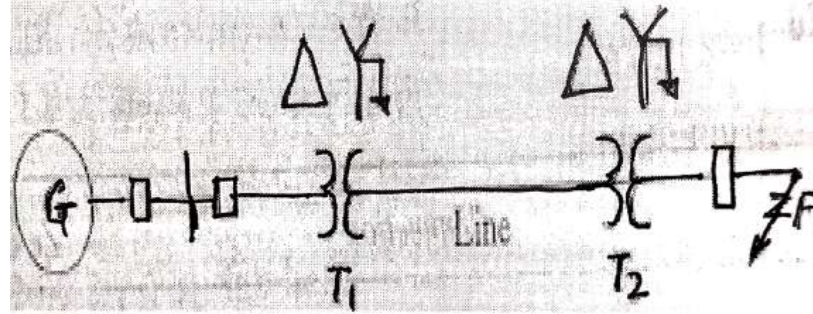

- b) Explain sequence impedance synchronous machine. 07

Section B

- Q.6 Attempt any five of the following: 10
- What is different between Xbus and Zbus.
 - Short note on how are buses classified.
 - Define load flow.
 - Give reasons NR method is based on Taylor series.
 - Which fault is more severe if it occurs at generator terminal and why.
 - Explain in brief interconnected power system.
- Q.7 a) Derive the necessary equation to determine double line to ground fault. 08
 b) Discuss the bus impedance matrix for analysis of unsymmetrical shunt fault. 07
- Q.8 a) Discuss the load flow problem. 08
 b) Give the comparison of load flow methods. 07
- Q.9 a) Explain in detail load dispatch center function. 08
 b) Explain emergency and restorative control. 07
- Q.10 a) Derive an expression for fast decoupled load flow method. 08
 b) Discuss the contingency analysis. 07

Total No. of Printed Pages:2

SUBJECT CODE NO:- H-1449
FACULTY OF SCIENCE AND TECHNOLOGY
T.Y. B.Tech. (Electrical) (Sem-VI)
Control System Engineering
[Revised]

[Time: Three Hours]

[Max. Marks:80]

Please check whether you have got the right question paper.

N.B.:

- Question no 1 from section A and Question no 6 from section B is compulsory.
- Solve any two from remaining questions from each section.
- Assume suitable data, if required.

Section – A

Q.1 Attempt any five of the following: 10

- a. Give example of open loop and closed loop control system.
- b. Write Mason’s Gain formulae.
- c. What is type and order of a system?
- d. Define rise time.
- e. Explain settling time.
- f. What are the advantages of generalized error series method.
- g. What are different Error Coefficient write the formula.

Q.2 a) Distinguish between 08

- i) Block diagram method and signal flow graph method.
- ii) Open loop and closed loop system.

b) Apply Masons Gain Formula to find C/R 07



Q.3 a) Find the transfer function of electrical network shown below. 08

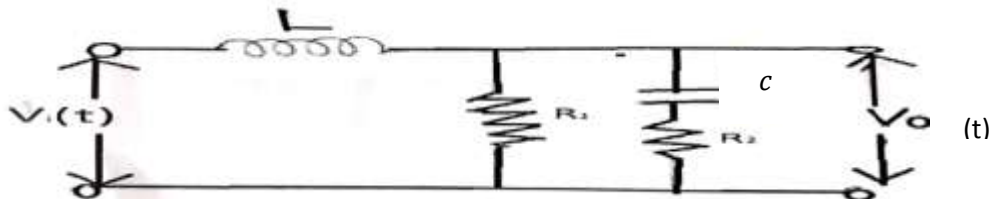

b) Explain the construction and working of Synchro-Transmitter. 07

Q.4 a) Determine the time response specifications for a unit step input to a unit negative feedback system having transfer function $G(s) = \frac{144}{s(s+12)}$ 08

b) Derive the transfer function for Lead compensation and draw its pole zero plot. 07

- Q.5 a) Compare between Armature Controlled and Field Control DC Servomotor 07
 b) Write the differential equation for the mechanical system shown below. Obtain an analogous electrical circuit based on Force-Current Analogy. 08

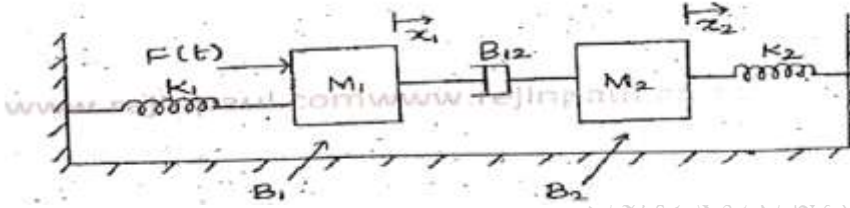

Section B

- Q.6 Attempt any five of the following: 10

- Define Phase Margin.
- State Nyquist Stability Criterion.
- Mention any four frequency response specification.
- What is BIBO stability criterion?
- Define bandwidth.
- Sketch time response plot under
 - Roots lying under imaginary axis.
 - Roots lying in R.H.S Plane
- Write the transfer function of PID controller

- Q.7 a) Sketch the root locus $G(s)H(s) = \frac{K}{s(s+1+j)(s+1-j)}$ ($K > 0$) 08

- b) Given $G(s)=1/s(s+1)(s+2)$. Draw the Nyquist plot and test the stability. Find W_{pc} , W_{gc} . 07

- Q.8 a) State and explain "Mapping Theorem". 07
 b) Sketch the polar plots for type 1 and type 2 systems. 04
 c) Sketch the root locus for open loop system $G(s)H(s) = K/s(s + 4)(s^2 + 2s + 2)$, Find stability. 04
 07

- Q.9 a) A unity feedback control system has open loop transfer function as: 08
 $G(s)=100/ s(1+0.1s) (1+0.2s)$. Sketch bode plot and determine from it:
 i) Gain crossover frequency ii) Phase crossover frequency
 iii) Gain margin iv) Phase margin
 b) State advantages and disadvantages of frequency & time domain analysis 07

- Q.10 Attempt any three of the following: 15
 (i) State advantages and disadvantages of frequency & time domain analysis
 (ii) Draw block diagram and discuss PD controller
 (iii) Write short notes on Potentiometer.
 (iv) State and explain the angle and magnitude condition for root locus technique in stable system.
 (v) State the effect of location of poles on stability.
 i) For all the poles located in LHS of s-plane
 ii) For poles on the jw-axis and simple
 iii) For all poles located in RHS-of-s-plane
 iv) Multiple poles at the origin

Total No. of Printed Pages:2

SUBJECT CODE NO:- H-1456
FACULTY OF SCIENCE AND TECHNOLOGY
T.Y. B.Tech. (Electrical) (Sem-VI)
Electrical Drives
[Revised]

[Time: Three Hours]

[Max. Marks:80]

- N.B.:
- Please check whether you have got the right question paper.
 - Question no 1 from section A and Question no 6 from section B is compulsory.
 - Solve any two from remaining questions from each section.
 - Assume suitable data, if required.

Section – A

- Q.1 Answer any five of the following: 10
- a) Define Electrical Drive system.
 - b) What is critical speed?
 - c) Define transient state stability
 - d) What are the advantages of Electrical Drive system?
 - e) What is a line commutated inverter?
 - f) What is dynamic braking?
 - g) What are the advantages of variable frequency control?
- Q.2
- a) Explain about the speed-torque conventions & multi-quadrant operation? 08
 - b) Derive the Expression for equivalent drive parameters of loads with Translational motion 07
- Q.3
- a) Explain the operation of chopper controlled of DC series motor. 08
 - b) A 3 phase, star connected, 50 Hz, 4 pole induction motor has the following parameter in ohms per phase referred to the stator. $R_s = R_r' = 0.034\Omega$ $X_s = X_r' = 0.18\Omega$. The motor is connected by the variable frequency control with a constant (V/f). Determine the following for an operating frequency of 15 Hz. i) the breakdown torque as a ratio of its value at the rated frequency for motoring and braking. ii) The starting torque and rotor current in terms of their values at the rated frequency. 07
- Q.4
- a) Explain the constant v/f control of Induction motor drives. 08
 - b) Explain the braking & multi-quadrant operation of VSI in Induction motor drives. 07
- Q.5
- a) What are the components of load torques & explain it 08
 - b) A 440 V, 50 Hz, 960rpm, star-connected wound rotor Induction Motor has: $R_s = 0.15\Omega$, $X_r' = 0.6\Omega$ and $X_m = 20\Omega$. The stator to rotor turns ratio is 2. This motor is controlled by a Rotor-chopper scheme. The filter inductor has a resistance of 0.01Ω . The external resistance is 4Ω . For a duty cycle of 0.7 and a speed of 600 rpm, evaluate the torque developed. 07

Section – B

- Q.6 Answer any five of the following: 10
- What are the electrical braking methods?
 - Define running torque.
 - What is the function of commutator less Dc motor.
 - Write the expression for time & energy loss in transient operation?
 - What are the advantages of cycloconverter drives?
 - High braking torque produced in _____
 - List the different modes of operation of a scherbius drive.
- Q.7 a) Explain the following methods in synchronous motor drive 08
- Starting
 - Braking
- b) Explain the Self-controlled synchronous motor drive fed with LCI. 07
- Q.8 a) Derive the expression for calculate the time loss in transient operations. 08
- b) Discuss with schematic diagram of sub-synchronous & super synchronous motoring modes of operation of static scherbius drive. 07
- Q.9 a) Explain with block diagram of direct vector control with rotor flux orientation. 07
- b) List the similarities & differences between a brushless DC motor & a conventional Dc motor. 08
- Q.10 a) Explain about the sugar mills in electrical drive system. 07
- b) Explain the different modes of variable frequency control of synchronous motor drive. 08

Total No. of Printed Pages:2

SUBJECT CODE NO:- H-1471
FACULTY OF SCIENCE & TECHNOLOGY
T.Y. B.Tech. (Electrical) (Sem-VI)
Electromagnetic Field
[Revised]

[Time: Two Hours]

[Max. Marks:40]

Please check whether you have got the right question paper.

- N.B
- Question no 1 from section A and Question no 6 from section B are compulsory.
 - Solve any two from remaining questions from each section.
 - Assume suitable data, if required.

Section A

- Q.1 Answer any three of the following: (06)
- a) Write down the relationship between Cartesian and spherical coordinate system.
 - b) Define Curl of vector.
 - c) Define absolute potential and explain it?
 - d) Write down procedure for solving Laplace equation.
 - e) Write the explicit form of Laplace equation for Cartesian and cylindrical coordinate system.
- Q.2 Explain cylindrical coordinate system and differential element in cylindrical coordinate system. (07)
- Q.3 State divergence theorem? (07)
- Q.4 Derive Laplace equation for finding the electric potential (coaxial cable capacitor). (07)
- Q.5 If A(1,-3,2) B(2,5,-4) C(-1,3,3) Find out following.
- 1) Vector AB 2) Vector BC 3) Vector CA 4) Magnitude of vector drawn from A & B.
 - 5) Unit vector directed from B to A 6) Vector from A to the midpoint of straight line.

Section B

- Q.6 Answer any three of the following: (06)
- a) State the stock theorem.
 - b) Write relationship between magnetic flux and magnetic flux density.
 - c) Define uniform plane wave.
 - d) What is concept of displacement of current?
 - e) Write the point form and integral form of maxwell's equation for good conductor.
- Q.7 Write the point form and integral form of maxwell's equations for time varying field. (07)

- Q.8 What is skin effect and write the equation to find skin depth over a good conductor. (07)
- Q.9 What are the boundary conditions? Explain. (07)
- Q.10 State and Explain stock theorem. (07)

Total No. of Printed Pages:2

SUBJECT CODE NO:- H-318
FACULTY OF SCIENCE AND TECHNOLOGY
T.E. (EEP/EE/EEE) (Sem-I)
Electromagnetic Fields
[OLD]

[Time: Three Hours]

[Max.Marks:80]

Please check whether you have got the right question paper.

N.B

1. Q. No. 1 and Q. No. 6 are compulsory.
2. Attempt any two questions from Q. No. 2 to Q.No.5.
3. Attempt any two questions from Q. No. 7 to Q. No. 10.
4. Assume suitable data wherever necessary.

Section -A

- Q.1 Attempt any five. 10
- a. Define scalar and vector Field. With examples.
 - b. Find $|\vec{F}|$ at $P(-4,3,5)$ if vector field $\vec{F} = 0.4(y - 2x)\hat{a}_x - \frac{200}{x^2+y^2+z^2}\hat{a}_z$
 - c. State Gauss Law, what do you mean by Gaussian surface?
 - d. Given vector; $\vec{A} = -\hat{a}_x - 3\hat{a}_y - 4\hat{a}_z$ and $\vec{B} = 2\hat{a}_x + 2\hat{a}_y + 2\hat{a}_z$ Find $\vec{A} \times \vec{B}$
 - e. Relate Cartesian co-ordinate (x,y,z) to spherical co-ordinate (r, θ, φ).
 - f. Define potential gradient.
 - g. Write the expression for differential surface area in cylindrical co-ordinate system.
 - h. Define Electric flux and flux density. Write relation between \vec{E} and \vec{b}
- Q.2 07
- a. State coulomb's Law. And to derive expression for coulomb's law in vector form. 07
 - b. Transform each of following vectors to cylindrical co-ordinates at point specified 08
 - i) $5\hat{a}_x$ at point $p(r = 4, \theta = 120^\circ, z = -1)$
 - ii) $5\hat{a}_x$ at point $p(x = 3, y = 4, z = -1)$
- Q.3 07
- a) Derive the expression for Electric field intensity due to infinite line charge of placed along Z-axis. 07
 - b) A line charge of 2×10^{-9} coulomb/m lies along y-axis, while surface charge densities of 0.1×10^{-9} and $-0.1 \times 10^{-9} \text{ C/m}^2$ exists. on the plane $z = 3, z = -4$ respectively. 08
 - i) Find \vec{E} at point $(1, -7, 2)\text{m}$
- Q.4 07
- a) State and explain divergence Theorem. 07
 - b) Given $\vec{D} = \frac{5r^2}{4} \hat{a}_r \text{ C/m}^2$ in spherical co-ordinate system calculate both sides of divergence theorem. For volume enclosed by $r = 4\text{m}$. $\theta = \frac{\pi}{4}$ radians. 08
- Q.5 07
- a) Derive the expression for potential and Electric field. At any point P in free space due to electric dipole. 07

b) If $v = 50x^2yz + 20y^2$, then at point $P(1,2,3)$ find (i) V (ii) E (iii) $\frac{dV}{dN}$ (iv) D .

08

Section – B

Q.6 Attempt any five.

10

- State Faradays Law.
- Define self and mutual inductance.
- What do you mean by vector magnetic potential and it's unit.
- Define Magnetic dipole moment.
- State uniqueness theorem.
- Justify expression $\nabla \cdot \vec{B} = 0$
- Define Magnetic field intensity and its unit.
- Give the unit of M_r and \vec{M} .

Q.7

- Derive the expression for integral and point form of continuity equation.
- Let two homogeneous linear isotropic Material have interface at $z = 0$ and $z < 0, M_{r1} = 2$ and $z > 0, M_{r2} = 4$. The flux density vector $B_1 = 1.8\hat{a}_x + 1.2\hat{a}_y + 0.6\hat{a}_z$ T is incident at the boundary. Find (i) B_2

07

08

Q.8

- For time varying field show that $\nabla \times \vec{E} = -\frac{\delta \vec{B}}{\delta t}$
- Find the total current in outward direction from a cube. Of 1m. with one corner at the origin and edges parallel to the co – ordinates axis if $\vec{J} = 2x^2\hat{a}_x + 2xy^3\hat{a}_y + 2xy\hat{a}_z$ A/m²

07

08

Q.9

- For the steady Magnetic field show that $\nabla \times \vec{H} = \vec{J}$
- Explain the term “SCALAR and VECTOR” Magnetic potential.

07

08

Q.10

- Attempt any three.
- State and explain Amperes circuital Law.
 - Magnetization in Magnetic Material.
 - Explain Maxwell's equation in integral form.
 - State and explain stokes theorem.

15

Total No. of Printed Pages:2

SUBJECT CODE NO:- H-576
FACULTY OF SCIENCE AND TECHNOLOGY
T.E.(EEP/EE/EEE) (CGPA) (Sem-II)
Testing And Maintenance Of Electrical Equipments
[REV]

[Time: Three Hours]

[Max.Marks:80]

Please check whether you have got the right question paper.

N.B

- i) Que.01 & Que.06 are compulsory.
 ii) Solve any two questions from the remaining questions of each Section.

SECTION A

- Q.1 Answer any five questions of the following:- 10
- What do you understand if color of silica gel in transformer breather is blue?
 - Define particular testing.
 - Define maintenance.
 - Define Direct testing.
 - Give two examples of indirect testing.
 - Define TPM.
 - Define Winding to winding short circuit fault.
- Q.2 (a) What are the reasons of overheating of transformer & give its effects. 07
 (b) Explain Need of conservator top up & radiator choking in detail. 08
- Q.3 (a) Explain concept of TPM & give its significances. 07
 (b) Define maintenance & explain different types of maintenance with examples. 08
- Q.4 (a) Explain the faults during manufacturing of transformer. 07
 (b) Differentiate between type test, routine test & special test. 08
- Q.5 Write a short note on: 15
- Tolerance
 - Magnetic imbalance in 3 ϕ I.M.
 - Excessive vibrations in 3 ϕ transformer

SECTION B

- Q.6 What effects you will observe if following condition occurs [Solve any five]: 10
- Winding to body short circuit in I.M.
 - Wrong placement of winding of coils in rotor.
 - Cracks in welded motor body.
 - Bearing is jammed.
 - Magnetic flux leaks from station.
 - Motor has excessive vibrations.

- (g) Rotor had a bend
- Q.7 (a) Explain I.M. testing methods as per ISS & name the equipments to identify each. 07
 (b) Describe the causes & effects of faults during the manufacturing of 3φ I.M. 08
- Q.8 (a) With neat diagram explain ultrasonic testing 07
 (b) Explain Heat run testing with neat diagram. 08
- Q.9 (a) Enlist the reason of faults during operation of Induction motor & give their effects. 07
 (b) Explain DGA testing & its procedure in detail with neat diagram. 08
- Q.10 Write a short note on 15
 a) Resistance testing methods
 b) H.V. withstand test
 c) Impregnation of polymer insulating material

Total No. of Printed Pages:02

SUBJECT CODE NO:- H-583
FACULTY OF SCIENCE AND TECHNOLOGY
T.E.(EEP/EE/EEE) (CGPA) (Sem-II)
Power Electronics-I
[Revised]

[Time: Three Hours]

[Max. Marks: 80]

N.B Please check whether you have got the right question paper.

- i) Q. No. 1 and Q. No. 6 are compulsory.
 ii) Solve any two questions from remaining from each section.
 iii) Draw appropriate wave forms if required.
 iv) Assume suitable data if necessary.

SECTION - A

- | | | |
|-----|--|----------|
| Q.1 | Solve any five. | 10 |
| | a) Draw the output characteristics of 'n' channel enhancement MOSFET.
b) Define the term gate recovery time.
c) What are different SCR voltage rating.
d) What are the different between fully controlled and half controlled rectifiers?
e) State the performance parameters of controlled rectifier.
f) What are different classification of chopper?
g) Compare circulating and non-circulating current mode of dual converter.
h) What are the advantages of dc chopper over controlled rectifiers? | |
| Q.2 | a) Draw construction features of MOSFET. Explain Pts switching characteristics.
b) Draw and explain the switching characteristics of SCR during its turn on and turn off process. | 08
07 |
| Q.3 | a) How does GTO differ from conventional Thyristor? Give the circuit symbol and static V-I characteristics of GTO. Also discuss the turn off process of GTO.
b) With neat circuit diagram explain the working principle of single phase semi converter draw its waveforms. | 08
07 |
| Q.4 | a) Explain the operation of 3 – ϕ half controlled converter with RL load.
b) A three phase half wave controlled rectifier supplying a constant load current of 30A, operated from three phase 400V (line) supply. Find the average load voltage at firing angle 45° . What value of current and peak reverse voltage rating will the thyristor require. | 08
07 |
| Q.5 | a) What is dual converter? Explain the basic principle of operation of ideal dual converter.
b) A single quadrant Type – A chopper is – operated with following specifications:
on time $t_{on} = 1\text{msec}$, off-time $t_{off} = 1.5\text{ msec}$ and ideal battery of 220V. Calculate.
1) Average and RMS output voltages.
2) Ripple and form factor. | 08
07 |

SECTION – B

- Q.6 Solve any five. 10
- What is inverter? What are the different type of inverter.
 - What are the specifications of power supplies used in industrial application?
 - What is SMPs?
 - What is duty ratio chopper?
 - What is cycloconverter? Give its classifications.
 - Compare 180° and 120° mode operation of VSI.
 - What are the advantages of PWM control?
 - What is power conditioner?
- Q.7 a) With neat circuit and waveform explain the working principle of six step VSI operates in 180° modes. 08
- b) The single phase full bridge inverter has a resistance load of 10 ohm and dc input voltage is $V_s=220V$. Determine. 07
- RMS output voltage at the fundamental frequency.
 - The output power P_0 .
- Q.8 a) What are the draw backs of square wave inverter? What are the techniques used to overcome the draw backs of Square wave inverter? 08
- b) Explain the control techniques for output voltage of chopper. 07
- Q.9 a) Explain with neat circuit and wave form the operating modes of buck converter. 08
- b) What is cyclo converter? Explain the basic principle of operating of cyclo converter. 07
- Q.10 a) Write short note on working principle of single phase ac voltage controller. 08
- b) A single phase full – bridge inverter is operated from 24V Battery and Supplying a resistive load of 05 ohm. Determine. 07
- Fundamental output volt
 - Fundamental output power
 - Switch ratings

Total No. of Printed Pages:2

SUBJECT CODE NO:- H-590
FACULTY OF SCIENCE AND TECHNOLOGY
T.E.(EEP/EE/EEE)(CGPA) (Sem-II)
Microcontroller & applications
[Revised]

[Time: Three Hours]**[Max. Marks:80]**

Please check whether you have got the right question paper.

- N.B
- 1) Solve three questions from each section.
 - 2) Q.1 & Q.6 are compulsory.
 - 3) Assume suitable data if necessary.
- Q.1 Solve (14)
- 1) How the bit addressing is distinguished from byte addressing.
 - 2) What is opcode & operand of an instruction.
 - 3) What is pipelining of 8086.
 - 4) What is the importance of band rate in 8051 microcontroller.
 - 5) What is the function of instruction decoder in 8086.
 - 6) Define the machine cycle.
 - 7) Explain the function of Queue for 8086 microprocessor.
- Q.2 (a) Explain in detail Architecture of 8086. (07)
 (b) Explain the different Addressing modes of 8086. (06)
- Q.3 (a) Explain in detail generation of 20 bit physical address in 8086. (07)
 (b) Enlist the data transfer instructions of 8086. Explain any four. (06)
- Q.4 (a) Explain in detail TCON special function Register of 8051. (07)
 (b) Write ALP to add ten bytes in internal RAM locations. Assume that number are stored starting from location 20H. Store the result (8 bit) at 30H. (06)
- Q.5 Write a short note on (any three)
- (a) Overview of 8051 microcontroller family. (05)
 - (b) Comparison of microprocessor & microcontroller (05)
 - (c) Logical instruction of 8051. (04)
 - (d) Subroutines (04)
- Section - B**
- Q.6 Solve the following Questions (14)
- (1) What is the use of internal RAM of 8051.

- (2) Explain the function of Part 1 of micro controller 8051.
- (3) Define Addressing mode.
- (4) Explain the working of canter in 8051 microcontroller.
- (5) Enlist different SFRS in 8051 microcontroller.
- (6) Explain function of DPTR in 8051 microcontroller.
- (7) What is the use of ALU in 8051.

- Q.7 (a) Explain in detail serial transmission mode 0 of 8051 microcontroller. (07)
 (b) Write a program to generate 2KHZ frequency on PI-4 bit use timer 0. (06)
- Q8 (a) It is required to interface 7 – segment display to 8051 micro controller. Draw the interfacing diagram and write a program to display the BCP digits 0 to 9. (07)
 (b) Explain function of port 0 in detail. (06)
- Q.9 (a) Draw a functional block diagram of 8051 & Explain. (07)
 (b) Explain in detail interrupt structure of 8051. (06)
- Q.10 Write short note on (any three)
- (a) Features of 8051 microcontroller (05)
 - (b) Serial interface of 8051 microcontroller (05)
 - (c) Part 1 of micro controller (04)
 - (d) SFRS of 8051. (04)

Total No. of Printed Pages:02

SUBJECT CODE NO:- H-613
FACULTY OF SCIENCE AND TECHNOLOGY
T.E. (CGPA) (EEP/EE/EEE) (Sem-II)
Energy Conservation and Audit
[Revised]

[Time: Three Hours]

[Max.Marks:80]

Please check whether you have got the right question paper.

N.B.

- 1) Question No.1 and question No.6 are compulsory
- 2) Attempt any two from remaining questions from each section
- 3) Assume suitable data if required

Section A

- | | | |
|-----|--|----------|
| Q.1 | Attempt any five of the following | 10 |
| | <ol style="list-style-type: none"> a) Define energy audit b) Mention the sources of Greenhouse gases c) State the types of energy audit d) What Law of thermodynamics? e) What is meant by Global- warming potential. f) Enlist any four instrument which are used for measurement with its application g) What is Emission trading h) What is meant by Evaporation ratio in case of steam boiler. | |
| Q.2 | <ol style="list-style-type: none"> a) What is BEE? Explain its role in energy conservation. b) Explain Energy efficiency opportunities in HVAC of refrigeration system | 07
08 |
| Q.3 | <ol style="list-style-type: none"> a) Explain in detail the steps to calculate boiler efficiency by indirect method. b) List out five energy conservation opportunities in boiler plant of a thermal power station. | 07
08 |
| Q.4 | <ol style="list-style-type: none"> a) Explain Affinity laws applicable to pumping systems, and list the energy conservation opportunities in pumping system in an industry. b) What is need of co- generation? Explain its principles and briefly explain the types of steam turbine co- generation. | 07
08 |
| Q.5 | <p>Write short notes on any three</p> <ol style="list-style-type: none"> a) CDM and its objectives b) Energy and sustainable development c) Energy Audit of HVAC system d) Energy conservation Act 2001 | 15 |

Section – B

- Q.6 Attempt any five of the following 10
- What are the different methods of financial evaluation.
 - What is meant by evaporation ratio in case of steam boiler.
 - Define “ton” refrigeration
 - Write the statement of second law of Thermodynamics
 - What is meant by Global warming potential
 - What is DSM
 - What is PI
 - For light system define room index.
- Q.7
- Briefly explain simple payback period and mention its advantages and disadvantages. 07
 - Explain the importance of power factor in energy conservation program. 08
- Q.8
- Explain various components of electricity billing as applicable to an industrial consumer. 07
 - A 10 KVAR, 415V rated P.F capacitor was found to be having terminal supply voltage of 440 volts. calculate the capacity of the P.F capacitor at the operating voltage. 08
- Q.9
- Explain in detail the procedure to carry out energy audit for steel plant 07
 - Explain working of maximum demand controller and APFC panel. 08
- Q.10 Write short note on (any three) 15
- Soft starter
 - Electronic ballast
 - Uncertainty and sensitivity analysis
 - Electricity billing and load management

Total No. of Printed Pages:2

SUBJECT CODE NO:- H-1010
FACULTY OF SCIENCE AND TECHNOLOGY
T.Y. B.Tech. (Electrical) (Sem-VI)
Power System Analysis
[Old]

[Time: Three Hours]

[Max.Marks: 80]

Please check whether you have got the right question paper.

N.B

1. Question no 1 from section A Question no 6 from section B is compulsory.
2. Solve any two from remaining questions from each section.
3. Assume suitable data, if required.

Section A

Q.1 Answer any five of the following : 10

- a) What are the components of power system and function of transformer?
- b) What is the need of base value?
- c) What is bus impedance matrix?
- d) What are symmetrical components?
- e) What are the purpose of short circuit analysis?
- f) Give reasons for fault on transmission lines.

Q.2 a) Draw the impedance diagram for electrical power system shown is Figure showing all impedance in per unit on a 100 MVA base. Choose 20 kV as a voltage base generator. 08

The three phase power and line to line rating are given below.

G1: 90 MVA, 20kV, $x=9\%$	T1: 80MVA, 20/200kV, $X=16\%$
T2: 80MVA, 200/20 kV, $X=20\%$	G2: 90MVA, 18kV, $x=9\%$
Line: 200 kV, $X=120\Omega$	Load : 200kV, $S=48MW+j64Mvar$

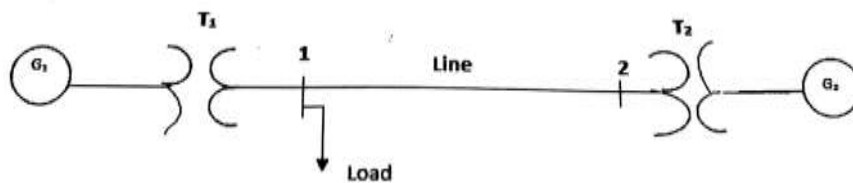

b) Explain in detail steady state model of synchronous machine. 07

Q.3 a) Explain the sequence network of transformer 08

- a. $Y - \Delta$
- b. $\Delta - \Delta$

b) Explain the Z-Bus formation and steps for building algorithm. 07

- Q.4 a) Explain the selection of circuit breakers. 08
 b) Derive the expression for transient on transmission line. 07
- Q.5 a) The voltage at the terminals of a balanced load consisting of three 20Ω Y- connected resistors are $200\angle 0^\circ$, $100\angle 255.5^\circ$, $200\angle 151^\circ V$. Find the line current from the symmetrical components of the line voltage's. 08
 b) A three phase Y- connected system is rated at 50MVA & 120kV. Express 40,000 kVA of 07 three phase apparent power as per unit value referred to a) the three phase system kVA as base and b) the per phase system kVA as base.

Section B

- Q.6 Answer any five of the following: 10
 a) Define sub transient reactance.
 b) Name the main difference in the representation of power system for load flow and short circuit studies.
 c) Write a short note on why the resistance is neglected for fault calculation?
 d) What is the difference between L-G and L-L fault.
 e) Only zero sequence current flows to the ground. Give the reason.
 f) What is bus impedance matrix?
- Q.7 a) Explain the major problems encountered in load flow studies. 08
 b) Explain fast decoupled method of algorithm for load flow studies. 07
- Q.8 a) Derive an expression to determine fault current for L-G fault. Draw the sequence network. 08
 b) Determine the fault current for L-L-G short circuit at the terminals of a star connected synchronous generator operating initially on an open circuit voltage of 10 p.u. The positive, negative and zero sequence reactance of the generator are respectively, $j 0.35$, $j 0.25$, and $j 0.20$ p. u and its star point is isolated from ground. 07
- Q.9 a) Explain in detail load dispatch center function. 08
 b) Explain the basic concept and system security functions in energy control center. 07
- Q.10 A) Discuss the Newton-Raphson method for solution of non-linear algebraic equations. 08
 B) Explain the contingency selection. 07

Total No. of Printed Pages:02

SUBJECT CODE NO:- H-1023
FACULTY OF SCIENCE AND TECHNOLOGY
T.Y. B.Tech. (Electrical). (Sem-VI)
Digital Signal Processing
[Old]

[Time: Three Hours]

[Max.Marks:80]

Please check whether you have got the right question paper.

N.B

- 1) Q.1 & Q.6 are compulsory.
- 2) Attempt any two questions from Q.2 to Q.5
- 3) Attempt any two questions from Q.7 to Q.10

Section A

- | | | |
|-----|--|----|
| Q.1 | Solve any five:- | 10 |
| | <ol style="list-style-type: none"> 1. Write about energy and power signal? 2. What are the limitations of DSP? 3. Draw the block diagram for digital signal processing system. 4. Explain Causal and Non causal Signal. 5. Write the equation for Z-transform. 6. What is Region of Convergence (ROC)? 7. What is Convolution property? | |
| Q.2 | a) Find the convolution of two finite duration sequences. 08
$h(n) = a^n u(n)$ for all n when $a \neq b$
$x(n) = b^n u(n)$ for all n when $a=b$ | |
| | b) Compute the convolution of DT 07
i. $x[n]=\{ 1 \ 2 \ 1 \ 2 \}$ $h[n]=\{1 \ 2 \ 3\}$ | |
| Q.3 | a) Write the short notes on following signal with suitable representation and diagram. 08
a. Unit Impulse signal
b. Unit Step signal
c. Unit Ramp signal
d. Exponential signal | |
| | b) Write the Properties of Region of Convergence (ROC). 07 | |
| Q.4 | a) Determine the Z-transform and ROC of $x(n) = a^n u(n) - b^n (-n - 1)$ 08 | |
| | b) Obtain Direct form –I realization for the system described by difference equation 07
$y(n) = 0.5y(n - 1) - 0.25y(n - 2) + x(n) + 0.4x(n - 1)$ | |

Q.5 a) Find the inverse Z-transform for

08

$$X(Z) = \frac{\frac{1}{4} Z^{-1}}{\left[1 - \left(\frac{1}{2}\right) Z^{-1}\right] \left[1 - \left(\frac{1}{4}\right) Z^{-1}\right]}$$

- a. $ROC |z| > \frac{1}{2}$ b. $ROC |z| < \frac{1}{4}$ c. $ROC \frac{1}{4} < |z| < \frac{1}{2}$

b) Write the steps to design an analog butterworth low pass filter and write the equation for magnitude function of the butterworth low pass filter design. 07

Section B

Q.6 Solve any five:

10

1. Write any four application of DSP.
2. What is the difference between analog filter and digital filter?
3. What is the advantage of digital filter design?
4. Write short notes on two types of Chebyshev filter.
5. Write short notes on filters with sine window.
6. What is the importance of Mann and Morrison algorithm?
7. What is power factor correction?

Q.7 a) Write the comparison between IIR and FIR.

07

b) Apply bilinear transformation to

08

$$H(s) = \frac{2}{(s+1)(s+2)} \text{ with } T=1 \text{ sec and find } H(Z)$$

Q.8 Write short notes on frequency transformation in analog domain and digital domain for following filter design.

15

- a. Low pass to high pass filter design
- b. Low pass to low pass filter design
- c. High pass to low pass filter design
- d. Low pass to band stop filter design

Q.9 a) Design 3rd order butter worth digital filter using impulse invariant method.

08

$$H(s) = \frac{1}{(s+1)(s^2+s+1)} \text{ assume sampling period } T=1 \text{ sec and find } H(z).$$

b) Explain in detail DSP application to machine control.

07

Q.10 Derive the equation for measurement of magnitude of voltage and current signal.

15

Total No. of Printed Pages:2

SUBJECT CODE NO:- H-1048
FACULTY OF SCIENCE AND TECHNOLOGY
T.Y.B.Tech.(Electrical) (Sem VI)
Electrical Drives
[OLD]

[Time: Three Hours]

[Max.Marks: 80]

Please check whether you have got the right question paper.

- N.B
- Question no 1 from section A and Question no 6 from section B are compulsory.
 - Solve any two questions from remaining in each section.
 - Assume suitable data, if required.

Section A

- Q.1 Answer any FIVE of the following. 10
- a) What is the function of power modulator?
 - b) Define windage torque.
 - c) Define Electrical drives.
 - d) What is meant by continuous and discontinuous conduction?
 - e) What are the applications of DC drive?
 - f) What are the advantages of closed loop system?
- Q.2 A) Explain the functions of essential parts of Electrical drives with the help of neat block diagram. 08
- B) Explain in detail four quadrant operation of a motor driving hoist load. 07
- Q.3 A) Explain how the speed of dc series motor can be controlled by means of dc chopper? 08
- B) The speed of 800 rpm, 80kW, 440V separately excited DC motor is controlled by a three phase full converter. The converter is fed from a three phase, 400V and 50 Hz supply. The armature resistance 0.8Ω and machine constant is 0.2 V/rpm . For rated current of 160 A. Find the firing angle for the machine when it is motoring at the rated speed. 07
- Q.4 A) Explain the comparison between CSI and VSI. 08
- B) Explain the operation of current source inverter fed Induction motor drive. 07
- Q.5 Write short notes on: 15
- i. Regenerative braking
 - ii. V/F control of Induction motor
 - iii. Load Equalization.

Section B

- Q.6 Answer any FIVE of the following 10
- What is v/f control of an Induction motor?
 - In 4-quadrant operation of a hoist 3rd quadrant represents _____
 - What are the electrical braking methods?
 - What is regenerative braking?
 - Write the expression for time & energy loss in transient operation?
 - List the different modes of operation of a scherbius drive.
 - Which braking is suitable for reversing the motor?
- Q.7 A) Explain the closed loop speed control LCI synchronous motor drive & list the advantages. 08
- B) Explain the True synchronous & self-synchronous modes of variable frequency control. 07
- Q.8 A) Derive the expression for calculate the time loss in transient operations. 08
- B) Discuss with schematic diagram of sub-synchronous & super synchronous motoring modes of operation of static scherbius drive. 07
- Q.9 A) Explain the construction & operation of brushless DC motor drive. 08
- B) List the similarities & differences between a brushless DC motor & a conventional Dc motor. 07
- Q.10 A) Explain the different modes of variable frequency control of synchronous motor drive. 08
- B) Explain about the textile mills in electrical drive application. 07

Total No. of Printed Pages:2

SUBJECT CODE NO:- H-1074
FACULTY OF SCIENCE AND TECHNOLOGY
T.Y. B.Tech. (Electrical) (Sem-VI)
Electromagnetic Field
[Old]

[Time: Three Hours]

[Max.Marks: 80]

Please check whether you have got the right question paper.

N.B

1. Q.1 & Q.6 are compulsory.
2. Attempt any two questions from each section.

SECTION – A

- Q.1 Solve any two. 10
- 1) Compare coordinate system.
 - 2) State and prove Divergence theorem.
 - 3) Derive equation of energy density is as electrostatic field.
- Q.2 a) Given $A = 5\hat{a}_x - 2\hat{a}_y + a\hat{z}$. Find the expression of unit vector a_B such that a_B is parallel to A. 07
- b) Explain cylindrical coordinate system. 08
- Q.3 a) Let $D = x ax$ and find the value $\int D \cdot ds$ over the surface of sphere $r=1$. 08
- b) Find electric field intensity due to semi-infinite straight uniformly charged wire at a point P, lying. 07
- Q.4 a) If $G = 5r \sin^2 \theta \cos^2 \phi Gr$ evaluate both sides up the divergence theorem for the region $r \leq 2$. 08
- b) Derive boundary condition for electric dielectric to dielectric boundary. 07
- Q.5 a) Explain in detail continuity of current. 08
- b) The polarization within a region having $Er = 2.7$ has uniform value $\vec{P} = -0.2 \hat{a}_x + 0.7 \hat{a}_y + 0.3 \hat{a}_z \mu c/m^2$ find \vec{E} and \vec{D} . 07

SECTION – B

- Q.6 Solve any two 10
- 1) Explain Ampere's law.
 - 2) Explain standing wave ratio.
 - 3) Derive boundary conditions for static Magnetic field.
- Q.7 a) Find the magnetic field intensity \vec{H} at point P(1,5,3) caused by a current filament to A is $0.8 \hat{x}$ direction on X-axis extending from -2 to 10 08
- b) State and explain Biot-savart law? 07
- Q.8 a) State and explain stoke's theorem. 08
- b) Write set of Maxwell's equations is time varying form. 07
- Q.9 a) Calculate value of vector current density is cylindrical coordinate at point P(1.5, 90°, 0.5) if $H = \frac{2}{\rho} \cos(0.2 \phi) a_\phi$ 08
- b) Justify the expression $\nabla \cdot \beta = 0$ 07
- Q.10 a) Given $\vec{E} = Em \sin(10^6 t - \beta z) \hat{a}_y$ V/M is free space. Find expression for $\vec{D}, \vec{B}, \vec{H}$ at $t = 1 \mu \text{ sec}$. 08
- b) Gives $\vec{H} = 300 \cos(3 \times 10^8 t - y) \hat{a}_z$ A/m . is free space. Find emf developed is the \hat{a}_ϕ direction about the close path having corners at (0,0,0), (1,0,0), (1,1,0) and (0,1,0). 07

Total No. of Printed Pages:01

SUBJECT CODE NO:- H-1157
FACULTY OF SCIENCE AND TECHNOLOGY
T. Y. B.Tech.(Electrical) (Sem-IV)
Electrical Testing & Maintenance
[Old]

[Time: Two Hours]

[Max.Marks: 40]

Please check whether you have got the right question paper.

- N.B
- 1) Question no. 1 from section A and Question no. 4 from section B is compulsory.
 - 2) Solve any two from remaining questions from each section.
 - 3) Assume suitable data from if required.

SECTION – A

- Q.1 Attempt any four of the following. 08
- i) Classify various types of transformer bushing?
 - ii) What is flash point test?
 - iii) Define hygroscoy
 - iv) Explain briefly induction motor fault monitoring method?
 - v) What is induction motor fault monitoring method?
- Q.2
- i) Explain different testing of transformer oil. 06
- OR
- ii) Explain planned maintenance of Induction motor. 06
- Q.3
- i) Explain Induction motor fault diagnostic method. 06
- OR
- ii) Explain various failure modes of Induction motor. 06

SECTION – B

- Q.4 Attempt any four of the following 08
- i) Explain the term touch potential.
 - ii) Define the term bedding.
 - iii) Explain dielectric loss factor.
 - iv) What is different methods for location of fault in power cable?
 - v) What are different types of earthing system?
- Q.5
- i) Explain the various testing of transformer IS 2026. 06
- OR
- ii) Explain various faults in power cables & the methods of locating cable faults. 06
- Q.6
- i) Explain & classify various substation based on constructional features. 06
- OR
- ii) Explain Kelvin's law & its limitation. 06

Total No. of Printed Pages:02

SUBJECT CODE NO:- H-1182
FACULTY OF SCIENCE AND TECHNOLOGY
T.Y. B.Tech.(Electrical) (Sem-V)
Power Electronics
[Old]

[Time: Three Hours]

[Max.Marks: 80]

Please check whether you have got the right question paper.

- N.B
- i. Question no1 from section A and Question no 6 from section B are compulsory.
 - ii. Solve any two from remaining questions from each section
 - iii. Assume suitable data, if required.

Section A

- Q.1 Answer any five of the following: 10
- a) Draw the TRIAC characteristics.
 - b) Define Latching current and Holding current.
 - c) What is Dual converter?
 - d) Why the power factor of semi-converter better than full converter?
 - e) What is a Snubber circuit?
 - f) Define the term: Displacement factor, THD.
 - g) What is freewheeling diode and what is the purpose?
- Q.2 a) Briefly explain about the basic structure of power MOSFET. 08
 b) Describe the methods of turn-on mechanism of SCR 07
- Q.3 a) Discuss the effect of source inductance on the performance of single phase full converter. 08
 b) Single- phase semi converter is operated from 110 V, 50 Hz ac supply. The load resistance is 15Ω . If the average output voltage is 25% of the maximum possible average output voltage, determine, (a) firing angle, (b) RMS and average output current, (c) RMS an average thyristor current. 07
- Q.4 a) A three-phase M-3 converter is operated from three-phase, 230 V, 50 Hz supply with load resistance of $R = 10\Omega$ and average output voltage is 50 % of the maximum possible output voltage is required. Determine: (i) firing Angle, (ii) Average and RMS value of load current, (iii) Rectification Efficiency. 08
 b) Discuss the effect of source inductance on the performance of three-phase full converter. 07
- Q.5 a) Draw the circuit of buck regulator and explain its working principle with necessary waveforms. Derive the expression for peak to peak ripple voltage of the capacitor that is present across the load. 08
 b) Note: Dual converter. 07

Section B

- Q.6 Answer any FIVE of the following: 10
- Mention any two advantages of CSI.
 - Define duty cycle of dc chopper.
 - Give any two important applications of AC Voltages controllers.
 - What are the control methods of chopper?
 - What is PWM?
 - Write the principle of operation of cycloconverter.
 - What is time ratio control in DC to DC converter?
- Q.7
- Explain with waveform multiple pulse width modulation inverters. 08
 - Write short notes on Current source inverter. 07
- Q.8
- Explain principle of step down chopper and derive expression for average Output voltage. 08
 - Explain the operation of class-C four quadrant chopper. 07
- Q.9
- Explain the operating principle of single-phase to single-phase cycloconverter with continuous and discontinuous load current. 08
 - What is mean by cycloconverter? What are its types? Explain advantages, disadvantages and its applications. 07
- Q.10
- Explain the working of Buck-Boost converter with neat waveform and also derive the expression for I_s . 08
 - Explain with neat waveform of three phase inverter for 120° conduction of each thyristor. 07

Total No. of Printed Pages:2

SUBJECT CODE NO:- H-1203
FACULTY OF SCIENCE AND TECHNOLOGY
T.Y. B.Tech.(Electrical) (Sem-V)
Microprocessor & Microcontroller
[Old]

[Time: Three Hours]

[Max.Marks:80]

Please check whether you have got the right question paper.

N.B

1. Q.1 and Q.6 is compulsory.
2. Attempt any two questions from section A and B.

Section A

- | | | |
|-----|--|----|
| Q.1 | Attempt any five of following: | 10 |
| | <ol style="list-style-type: none"> a) Draw flag register of 8085. b) Define instruction cycle and machine cycle. c) Write addressing modes of following instructions. <ol style="list-style-type: none"> i) MVI A, 084 ii) LDA 20004 iii) RLC iv) LXI H , 2500H d) Explain function of i) HOLD ii) HLDA pin. e) Enlist different data transfer schemes of 8085. f) Write any four indirect addressing mode instructions. | |
| Q.2 | a) Draw timing diagram for MVIA, 08H. | 08 |
| | b) Sketch architecture of 8085. | 07 |
| Q.3 | a) Differentiate between memory mapped i/o and i/o mapped i/o. | 08 |
| | b) Write subroutine program of 8085 to generate a delay of 10 m sec. | 07 |
| Q.4 | a) Draw block diagram of 8255. Explain each block configure 8255 with port A as output in mode o part B – i/p mode o and port C as input. | 08 |
| | b) Write a subroutine programme to generate triangular wave using DAC. | 07 |
| Q.5 | a) Explain addressing modes of 8086 with proper example. | 08 |
| | b) With neat diagram explain interfacing of seven segment display with 8085 using 8255. Draw complete address map. | 07 |

Section – B

- Q.6 Attempt any five of the following 10
- a) What is function of \overline{EA} pin of 8051
 - b) Write addressing modes of
 - i) MOV A, @ Ro ii) MOV A, # 06H iii) MOV A, Ro iv) MOV A, 06H
 - c) Write alternate functions of part 3 of 8051.
 - d) Give the function of DPTR register.
 - e) Enlist addressing modes of 8051.
 - f) Mention interrupter of 8051.
-
- Q.7 08
- a) Compare Microprocessor and Micro controller.
- 07
- b) Write a program to generate a delay of 200 m sec using timer of 8051.
-
- Q.8 08
- a) Explain following instructions
 - i) MOVX A, @ Ro ii) MUL AB iii) ADDA, # 09H iv) ADD A, RO07
 - b) With neat sketch describe interfacing of LCD with 8051.
-
- Q.9 08
- a) Sketch architecture of 8051.
- 07
- b) Draw and explain TMOD register of 8051.
-
- Q.10 08
- a) Compare PIC microcontroller with 8051.
- 07
- b) Explain the concept of RISC and CISC.

Total No. of Printed Pages:03

SUBJECT CODE NO:- H-1272
FACULTY OF SCIENCE AND TECHNOLOGY
T.Y.B.Tech.(Electrical) (Sem-V)
Control System Engineering
[OLD]

[Time: Three Hours]

[Max. Marks: 80]

Please check whether you have got the right question paper.

- N.B
- i. Question no 1 from section A and Question no 6 from section B is compulsory.
 - ii. Solve any two from remaining questions from each section.
 - iii. Assume suitable data, if required.

Section A

Q.1 Attempt any five from the following : 10

- a) What is damped frequency of oscillation?
- b) State Mason's gain formula.
- c) Define transfer function.
- d) Why negative feedback is invariably preferred in closed loop system?
- e) Define Damping ratio.
- f) Distinguish between type and order of a system.
- g) What is rise time and percentage overshoot?

Q.2 a) Determine the overall transfer function $C(s)/R(s)$ from the system shown in fig. 08

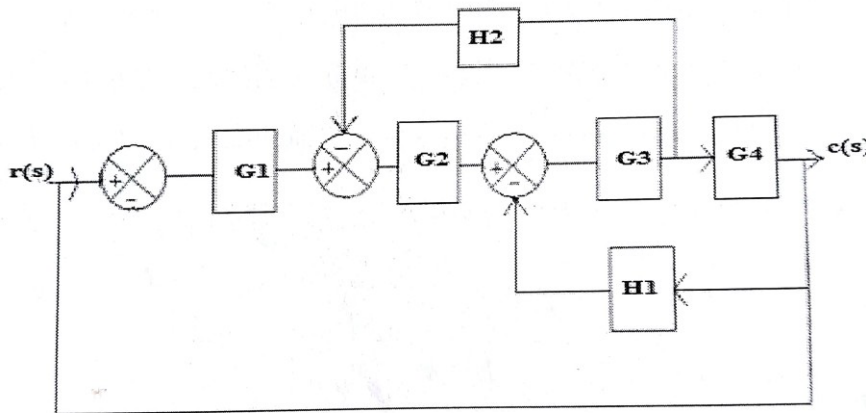

- b) Write the differential equations governing the Mechanical system shown in fig. and determine the transfer function. 07

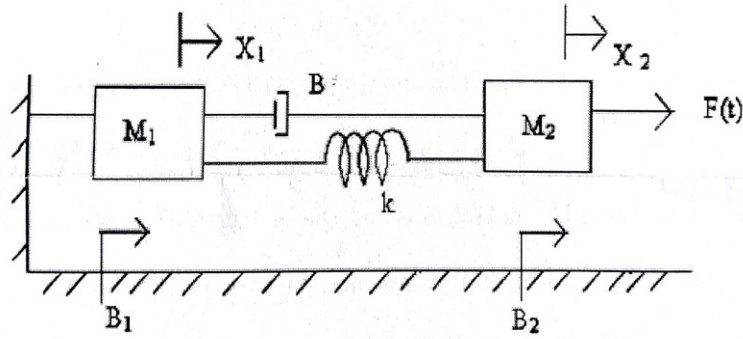

- Q.3 a) Derive the transfer function for Armature controlled DC servo motor. 08
 b) Derive the transfer function of phase lag network with neat circuit and block diagram. 07
- Q.4 a) Derive the expression and draw the response of the second order system for unit step input. 08
 b) The open loop transfer function of a servo system unity feedback is given by 07

$$G(S) = \frac{10}{(s+2)(s+5)}$$
 determine the damping ratio, undamped natural frequency of oscillation. What is percentage overshoot of the response to a unit step input?
- Q.5 a) For a unity feedback control system the open loop transfer function is given by, 08

$$G(S) = \frac{10(s+2)}{s^2(s+1)}$$
 find (i) Position, velocity and acceleration error constants.
 b) The open loop transfer function of a unity feedback system is given by, 07

$$G(S) = \frac{k}{(s+2)(s+4)(s^2+6s+25)}$$
 Determine the value of k and corresponding oscillation frequency.

Section B

- Q.6 Attempt any five from the following : 10
 a) Define the gain margin and phase margin.
 b) What is mean by gain crossover frequency and phase cross over frequency?
 c) Define BIBO stability?
 d) What are the compensators?
 e) What are the advantages of Bode Plot?
 f) What are the advantages of frequency response analysis?
 g) What is break-away and break in point?
- Q.7 a) Sketch the root locus for the open loop transfer function of unity feedback control 08
 system given below: $G(S)H(S) = K(S + 9)/S(S^2 + 4S + 11)$

- b) Using ROUTH criterion determine the stability of the system whose characteristics equation is $S^4 + 8S^3 + 18S^2 + 16S + 5 = 0$ 07
- Q.8 a) Sketch the bode plot and hence find gain cross over frequency, phase cross over frequency, gain margin and phase margin for system whose transfer function is, $G(S) = 10/S(1 + 0.4S)(1 + 0.1S)$ 08
- b) Explain the polar plots and Nyquist plots in stability analysis. 07
- Q.9 a) Explain the PI controller with neat block diagram and transfer function. 08
- b) Explain the frequency domain specification with the help of neat sketch. 07
- Q.10 a) The open loop transfer function of a unity feedback system is $G(S) = 1/S(1 + S)(1 + 2S)$ Sketch the polar plot and determine the Gain margin and phase margin. 08
- b) State the salient feature of Root locus and discuss the procedure to sketch root locus. 07

Total No. of Printed Pages:2

SUBJECT CODE NO:- H-1307
FACULTY OF SCIENCE AND TECHNOLOGY
T.Y.B.Tech.(Electrical) (Sem-V)
Transmission & Distribution
[OLD]

[Time: Three Hours]

[Max. Marks: 80]

Please check whether you have got the right question paper.

- N.B
1. Question no.1 from section A and question no.6 from section B is compulsory.
 2. Solve any two from remaining questions from each section.
 3. Assume suitable data. If required.
- Section A
- Q.1 Attempt any five of the following. 10
- a) Name the important components of an overhead transmission line.
 - b) Short note on various conductors material used for overhead lines.
 - c) Discuss the various types of line supports.
 - d) What do you understand by the constant of an overhead transmission line?
 - e) How does skin effect vary with conductor material?
 - f) What is effect of unsymmetrical spacing of conductors in a 3 – phase transmission line.
 - g) Name the important components of an overhead transmission line.
- Q.2 08
- a) Explain various methods of improving strings efficiency.
 - b) Deduces an approximate expression for sag in overhead line when, support are equal level and supports are unequal level. 07
- Q.3 08
- a) Derive an expression for inductances of composite conductor lines.
 - b) Derive an expression for inductances of three phase lines. 07
- Q.4 08
- a) Derive an expression for capacitances of a three phase line with equilateral spacing.
 - b) Explain method of Images and derive an expression for capacitances of a three phase line. 07
- Q.5 08
- a) Explain the various methods for reducing corona effect in an overhead transmission line.
 - b) A transmission line has a span of 150 meters between level supports. The conductor has cross section area of 2 cm^2 the tension in the conductor is 2000 kg. If special gravity of the conductor material is 9.9 gm/cm^3 wind pressure is 1.5 kg/m length, calculate sag. What is the vertical sag? 07

Section – B

- Q.6 Attempt any five of the following 10
- Why is leakage conductance negligible in overhead lines?
 - Why do we analysis a 3 – phase transmission line on single phase basis.
 - Write short note on why overhead system can be operated at 400 kV voltages.
 - Explain the terms voltage regulation and transmission efficiency as applied to transmission line.
 - What should be the desirable characteristic of insulator material used in cable?
 - Why are VIR Cables preferred to paper insulated cables for smaller installation?
 - Why is leakage conductance negligible in overhead lines?
- Q.7 a) Derive an expression for power flow through transmission line. 08
- b) Draw and explain sending end and receiving end power circle diagram. 07
- Q.8 a) Explain in detail the complete a.c.system for distribution of electrical energy. 08
- b) Explain in details ring main system and radial system. 07
- Q.9 a) Deduce an expression for the capacitance of a single core cable. 08
- b) Compare the merits and demerits of underground system versus overhead system. 07
- Q.10 a) What is mean by underground cable. Explain construction of cables. 08
- b) Explain power transmission capability and turned power line. 07

Total No. of Printed Pages:2

SUBJECT CODE NO:- H-1355
FACULTY OF SCIENCE AND TECHNOLOGY
T.Y.B.Tech.(Electrical) (Sem -V)
Energy Management
[OLD]

[Time: Two Hours]**[Max.Marks:40]**

Please check whether you have got the right question paper.

N.B

- i) All questions are compulsory.
- ii) Assume suitable data, if required.

Section A

- Q.1 Attempt any four of the following: 08
- i) Classify energy sources.
 - ii) What are the types of energy audit?
 - iii) What is Energy Management?
 - iv) List four instruments needed for energy audit.
 - v) Define energy management strategy.
- Q.2 a) What is the energy scenario in the India? 06
- OR
- b) What are the principles of energy auditing? Explain. 06
- Q.3 a) Explain why energy audit is needed? 06
- OR
- b) What are the duties of energy manager? 06

Section B

- Q.4 Attempt any four of the following: 08
- i) Define Report Writing?
 - ii) What is waste heat recovery?
 - iii) What mean by steam systems?
 - iv) Write two points comes under energy conservation for Air Conditioning.
 - v) List down the components in steam system.
- Q.5 a) Explain various energy conservation opportunities in an industry. 06
- OR
- b) Explain the efficient system for illumination. 06
- Q.6 a) Calculate simple payback period and % return on investment (ROI) for a project that cost Rs.100 Lakhs and Rs 5 Lakhs on an average to maintain and operate and is expected to save annually Rs.20 Lakhs. Comment on ROI whether to implement on the project. 06

OR

- b) Explain the following financial appraisal techniques.
 - i) Blower efficiency
 - ii) Opportunities of energy conservation in home

Total No. of Printed Pages:02

SUBJECT CODE NO:- H-1386
FACULTY OF SCIENCE AND TECHNOLOGY
T.Y. B.Tech.(Electrical) (Sem-V)
Power Electronics
(Revised)

[Time: Three Hours]

[Max.Marks:80]

Please check whether you have got the right question paper.

- N.B
- i. Question no 1 from section A and Question no 6 from section B are compulsory
 - ii. Solve any two from remaining questions from each section
 - iii. Assume suitable data, if required.

Section A

- Q.1 Answer any five of the following:- 10
- a) What is a Snubber circuit?
 - b) Draw the circuit for six-pulse mid-point converter with inductive load.
 - c) What is Dual converter?
 - d) List the various forced commutation techniques used to turn-off the SCR.
 - e) What is freewheeling diode and what is the purpose?
 - f) Define Latching current.
 - g) Define the term: Displacement factor, THD.
- Q.2
- a) Describe the methods of turn-on mechanism of SCR. 08
 - b) Explain the basic block diagram of power electronic system. 07
- Q.3
- a) Explain with neat waveform about the operation of a single phase fully controlled Mid-point converter with resistive load. 08
 - b) Describe briefly the working of Dual converter with a neat circuit diagram. 07
- Q.4
- a) Explain with circuit and output waveform working of three phase half controlled converter with R load. 08
 - b) Discuss the effect of source impedance on the performance of three-phase full bridge converter. 07
- Q.5
- a) Explain Rectifying mode and inverting mode in detail. 08
 - b) Explain the types of phase controlled converter in detail. 07

Section B

- Q.6 Answer any FIVE of the following: 10
- a) What is constant frequency system?
 - b) What is two-quadrant DC Chopper?
 - c) What is time ratio control?
 - d) Write the principle of operation of cycloconverter.
 - e) What are the applications of cycloconverter?

- f) Compare VSI and CSI.
 - g) What is the advantage of 120° mode of inverter operation over 180° mode?
- Q.7
- a) Describe with basic circuit and waveform the principle of operation of Step-up chopper. 08
 - b) What is chopper? Explain its classification in detail. 07
- Q.8
- a) Explain with neat waveform of three phase inverter for 180° conduction of each thyristor. 08
 - b) Explain the single phase full bridge inverter with resistive load. 07
- Q.9
- a) Describe the basic principle of working of single-phase to single-phase cycloconverter. 08
 - b) Write short notes on: Integral cycle control and Multistage sequence control. 07
- Q.10
- a) Describe the basic principle of working of three-phase to single-phase cycloconverter. 08
 - b) Explain the operation of Class-C two-quadrant chopper. 07

Total No. of Printed Pages:2

SUBJECT CODE NO:- H-1393
FACULTY OF SCIENCE AND TECHNOLOGY
T.Y.B.Tech.(Electrical) (Sem-V)
Microprocessor & Microcontroller
(Revised)

[Time: Three Hours]**[Max.Marks:80]**

Please check whether you have got the right question paper.

- N.B
- i) Q.1. and Q.6 are compulsory.
 - ii) Attempt any 2 questions from each section.

Section A

- | | | |
|-----|---|---------------------|
| Q.1 | Attempt any five of following. | 10 |
| | <ol style="list-style-type: none"> a) Enlist different data transfer schemes of 8085. b) Write different instructions used in memory mapped i/o. c) Write any four indirect addressing mode instructions. d) Give addressing modes of following instructions <ol style="list-style-type: none"> i) LXIH, 2800H ii) MOV B,M iii) IN 80H iv) OUT 80H. e) Draw flag register of 8085. f) Write instructions to reset bit no.3 of port C of 8255. | |
| Q.2 | <ol style="list-style-type: none"> a) Explain addressing modes of 8085 with proper examples. b) Draw timing diagram of MVIA, 08H. | <p>08</p> <p>07</p> |
| Q.3 | <ol style="list-style-type: none"> a) Draw and explain interfacing of Relay with 8085 using 8255. Give complete address map. Write a program to turn on the bulb for 1 minute. b) Describe control word register of 8255 in BSR mode. with neat diagram write a program for blinking of LED connected to port C bit no.6. | <p>08</p> <p>07</p> |
| Q.4 | <ol style="list-style-type: none"> a) Explain addressing modes of 8086 with proper example. b) Describe programming model of 8086 with neat diagram. | <p>08</p> <p>07</p> |
| Q.5 | <ol style="list-style-type: none"> a) Explain following instructions of 8086. <ol style="list-style-type: none"> i) XCHG AL, BL ii) SBB DL, CL iii) MUL BL iv) DAA b) Describe minimum mode of 8086 with proper diagram. | <p>08</p> <p>07</p> |

Section B

- Q.6 Attempt any five of the following. 10
- Give the function of PSEN pin of 8051.
 - Write addressing modes of following instructions.
 - MOV A, @ RO
 - ADD A, # 05H
 - MOV A, RO
 - MOV A, 40H
 - Draw SCON register format.
 - Enlist serial communication modes of 8051.
 - Why stack pointer of 8051 is 8 bit wide?
 - Why 11.0592 MHz frequency is used for 8051?
- Q.7 a) Explain following instructions of 8051. 08
- ANLA, # 04 H
 - XRLA, # 40H
 - SWAP A
 - RLA
- b) Explain memory organization of 8051 microcontroller. 07
- Q.8 a) Sketch architecture of 8051. 08
- b) Draw SCON register format. Write a program to send a character “A” continuously. 07
- Q.9 a) Draw and explain interfacing of DAC with 8051. Write a program to generate triangular wave. 08
- b) Write a program to generate a square wave of 1 KHz frequency using timer of 8051. 07
- Q.10 a) Describe memory organization of PIC microcontroller. 08
- b) Give the features of PIC family. 07

Total No. of Printed Pages:02

SUBJECT CODE NO:- H-1400
FACULTY OF SCIENCE AND TECHNOLOGY
T.Y. B.Tech.(Electrical) (Sem-V)
Digital Signal Processing
(Revised)

[Time: Three Hours]

[Max.Marks:80]

Please check whether you have got the right question paper.

- N.B
- i. Q.1 & 6 are compulsory
 - ii. Attempt any two questions from Q.2 to Q.5
 - iii. Attempt any two questions from Q.7 to Q.10

Section A

- | | | |
|-----|--|--|
| Q.1 | Solve any five | 10 |
| | <ol style="list-style-type: none"> 1. What is the difference between linear convolution and circular convolution? 2. What are the advantages of DSP? 3. Draw the block diagram for digital signal processing system 4. Define Periodic and Aperiodic Signal? 5. Write the discrete time expression for Z-transform 6. Define DFT time reversal property. 7. Define transfer function | |
| Q.2 | a) Find the convolution of two finite duration sequences
$h(n) = a^n u(n) \text{ for all } n$ $x(n) = b^n u(n) \text{ for all } n$ <div style="display: flex; justify-content: space-between; margin-left: 150px;"> when $a \neq b$ when $a = b$ </div>
b) Define the following topics <ol style="list-style-type: none"> i. Quantization ii. Quantization error iii. Nyquist rate iv. Aliasing effect | 08

02
01
02
02 |
| Q.3 | a) Write the short notes on the following systems with suitable representations and diagram. <ol style="list-style-type: none"> i. Stable and Unstable ii. Linear and Nonlinear systems iii. Invertible and Non-invertible systems
b) Write any two Properties of Z-transform | 03
02
02

08 |
| Q.4 | a) Find the DFT of a sequence $x(n) = \{1,2,3,4,4,3,2,1\}$ using DIT algorithm

b) Obtain Direct form-I realization for the system described by difference equation
$y(n) = 0.5y(n-1) - 0.25y(n-2) + x(n) + 0.4x(n-1)$ | 08

07 |

- Q.5 a) Write the steps to design an analog Chebyshev low pass filter 09
 b) Write comparison between Butterworth filter and Chebyshev filter 03
 c) Give the Chebyshev filter transfer function equation. 03

Section B

- Q.6 Solve any five 10

1. Write any four application of DSP processor
2. What is the difference between analog filter and digital filter?
3. What is the advantage of digital filter design?
4. Write short notes on two types of Chebyshev filter.
5. Draw the direct form realization of FIR filter design
6. What are the classification digital signal processor?
7. What are the limitations of DSP?

- Q.7 a) Explain in detail about Harvard architecture. 08
 b) Describe in detail about architecture of TMS320C54X processor 07

- Q.8 Explain the following topics with frequency response 15

- a) Rectangular window
- b) Hanning window
- c) Hamming window
- d) Blackman window
- e) What is Hilbert transform?

- Q.9 a) Design 3rd order Butterworth digital filter using impulse invariant method. 08

$$H(s) = \frac{1}{(s+1)(s^2+s+1)}$$

assume sampling period $T = 1$ sec and find $H(z)$

- b) Apply bilinear transformation to $H(s) = \frac{2}{(s+1)(s+2)}$ with $T = 1$ sec and find $H(z)$ 07

- Q.10 a) Describe in detail about sub band coding of speech signal 07
 b) Describe in detail about oversampling A/D and D/A conversion 08

Total No. of Printed Pages:2

SUBJECT CODE NO:- H-1407
FACULTY OF SCIENCE AND TECHNOLOGY
T.Y.B.Tech.(Electrical) (Sem-V)
Design of Electrical Machines
(Revised)

[Time: Three Hours]

[Max.Marks:80]

Please check whether you have got the right question paper.

- N.B
1. Question No.1 from section A and questions no.6 from section B is compulsory.
 2. Solve any two from remaining questions from each section.
 3. Assume suitable data if required.

Section A

- Q.1 Attempt any five of the following: 10
- a) What happens if there is insufficient rating of the machine?
 - b) What is one important criteria related to the power ratings of the machine?
 - c) What is the range of frequency during the selection of number of poles?
 - d) What are magnetic hard materials?
 - e) What happens to the length of the commutator with the increase in number of poles?
 - f) What should be the range of the current per brush arm?
 - g) What should be the armature mmf per pole for output over 1500 kW?
- Q.2
- a) Give the rating, specification and standards of electrical machines. 08
 - b) What are the classifications of insulating materials? Give the example. 07
- Q.3
- a) Draw a neat sketch of lifting electromagnets and derive its equations for magnetic pull. 08
 - b) Discuss the design of choke calculation. 07
- Q.4
- a) Draw a winding diagram for a 4 pole, 36 slots and 3 phase mush connected armature. 08
 - b) Give the layout of lap winding for the stator of a 3 phase ac machine having 4 pole, 24 slots. There are 2 coil sides per slot. 07
- Q.5
- a) Draw and explain hemitropic winding and whole coil winding. 08
 - b) Explain in detail layout of frictional slot winding. 07

Section – B

- Q.6 Attempt any five of the following: 10
- What is the relation of the transformer surface with respect to dissipation of heat?
 - How is the circulation of oil improved in tanks with tubes?
 - What is the formula for temperature rise with tubes?
 - What does the window space factor depends on?
 - What is the empirical formula for calculating the value of window space factor?
 - What are the ratings of the transformers for using the empirical value of window space factor?
 - Give the advantages of computer aided design of electrical machines.
- Q.7 a) Derive the equations of temperature rise with time in electrical machine. What is heating time constant? 08
- b) A 250 V, 1 kW, single element resistor is made from 0.2mm thick nickel chrome strip. The temperature rise of strips is not to exceed 300°C over the ambient temperature of 30°C. calculate the length and width of a strip. Assume, emissivity= 0.9 radiating efficiency = 0.75 resistivity of nickel chrome $1 \times 10^{-6} \Omega m$. 07
- Q.8 a) Draw a schematic of a three phase core type transformer as well as shell type transformer along with respective phasor diagram. 08
- b) Develop the output equation for three phase transformer. 07
- Q.9 a) Draw and explain flow chart (i) main dimension (ii) armature winding of D.C. machine. 08
- b) Draw and explain flow chart for i) yoke ii) L.V and H.V winding of transformer. 07
- Q.10 a) Explain importance of computer aided design of electrical machine. 08
- b) Explain different types of cooling systems for cooling of electrical machines. 07

Total No. of Printed Pages:2

SUBJECT CODE NO:- H-1414
FACULTY OF SCIENCE AND TECHNOLOGY
T.Y. B.Tech. (Electrical) (Sem-V)
Transmission & Distribution
(Revised)

[Time: Three Hours]

[Max.Marks:80]

- N.B Please check whether you have got the right question paper.
1. Q.No.1 from section A and Q.No.6 from section B is compulsory.
 2. Solve any two from remaining questions from each section.
 3. Assume suitable data, if required.

Section A

- Q.1 Attempt any five of the following 10
- a) Classify Insulator with voltage range.
 - b) What is skin effect?
 - c) What is charging current?
 - d) What is a structure of bundled conductor?
 - e) What is the effect of ice and wind loading on conductor of transmission line?
 - f) In brief explain about resistance of transmission system.
 - g) What is string efficiency?

- Q.2 08
- a) Derive the equation for sag at equal height.
 - b) Derive the equation for voltage distribution across the string. 07

- Q.3 08
- a) A conductor consists of seven identical strands each having a radius r , arranged as shown. Determine the factor by which r should be multiplied to find the self GMD of the conductor. 08

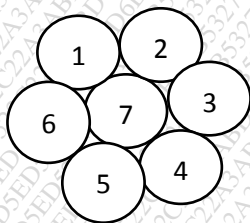

- b) Derive the equation for Inductance of single-phase two wire lines. 07
- Q.4 08
- a) Derive the expression for Pi method medium transmission line with proper phasor diagram.
 - b) Explain skin effect and proximity effect with necessary diagram. 07
- Q.5 08
- a) Explain the phenomenon of corona. State the formula for critical disruptive voltage.
 - b) Derive the equation for capacitance of a three-phase line with symmetrical spacing's. 07

Section B

- Q.6 Attempt any five of the following 10
- State the values of ABCD parameters for long transmission method.
 - What is transposition of lines?
 - Draw the equivalent circuit and phasor diagram for Pi method.
 - Give classification of insulating materials used in cables.
 - What are the three main requirements of the insulating materials used for cables?
 - What is the effect on transmission line parameters when distance between the conductors increases?
 - Define voltage regulation for transmission line?
- Q.7
- Explain the nominal Tee method with expressions and phasor diagram. 08
 - Explain and derive equation for power flow through transmission line. 07
- Q.8
- Explain ring main and radial system. 08
 - Derive the equation for insulation resistance of cables. 07
- Q.9
- Derive the equation for surge impedance loading and explain. 08
 - What is the effect of atmospheric conditions on transmission line in different areas? 07
- Q.10
- What are the advantages and disadvantages of corona? 08
 - Explain the construction of cable with neat diagram. 07

Total No. of Printed Pages:01

SUBJECT CODE NO:- H-1433
FACULTY OF SCIENCE AND TECHNOLOGY
T.Y.B.Tech.(Electrical) (Sem-V)
Elective-II Special Purpose Electrical Machines
[Revised]

[Time: TWO Hours]

[Max.Marks:40]

Please check whether you have got the right question paper.

N.B

- 1) Question no 1 from section A and Question no 4 from section B is compulsory.
- 2) Solve any one from remaining questions from each section.
- 3) Assume suitable data, if required.

SECTION "A"

Q.1 Attempt any five of the following 10

- 1) State the principle of switched reluctance motor.
- 2) What is meant by eddy current?
- 3) Draw the torque speed characteristics of induction two phase servo motor.
- 4) What are the various stator current modes used in synchronous reluctance motor?
- 5) Compare dc and ac servo.
- 6) State the operations of eddy current coupling.

Q.2 a) Explain operation of reluctance motor. 05

OR

b) Explain any one method of control of dc servo motor. 05

Q.3 a) Explain operation of dynamometer. 05

OR

b) Explain production of torque of dc servo motor. 05

SECTION "B"

Q.4 Attempt any five of the following: 10

- 1) What is AC tachogenerator?
- 2) State the advantages of induction tachogenerator.
- 3) What does mean by non linearities?
- 4) What is linear motor?
- 5) Draw the dynamic characteristics of AC tachogenerator.
- 6) State the applications of linear motor.

Q.5 a) Explain the reasons for deviations from desired characteristics of induction tachogenerator. 05

OR

b) Explain constructional features of synchros. 05

Q.6 a) Explain the principle and working of synchrotransformer. 05

OR

b) Explain the two dimensional field pattern of linear induction motor. 05

Total No. of Printed Pages:3

SUBJECT CODE NO:- H-107
FACULTY OF SCIENCE AND TECHNOLOGY
T.E. (EEP/EE/EEE) (Sem-II)
Electrical Machine design
[OLD]

[Time: Three Hours]

[Max.Marks:80]

Please check whether you have got the right question paper.

- N.B
1. Q .no. 1 and Q.no.6 are compulsory
 2. Attempt any two question from remaining question of each section
 3. Assume suitable data wherever necessary.

Section -A

- Q.1 Attempt any five 10
- a) What is the significance of standardization and specification in electrical machine design?
 - b) Why it is difficult to calculate MMF for air gap of a slotted machines.
 - c) State simpson's rule for calculation of MMF.
 - d) State the advantages of semi open slots used in induction motor.
 - e) What do you mean by output coefficient in rotating machine?
 - f) Why rotor conductors of squirrel cage rotor are not provided with insulation.
- Q.2
- a) Derive the expression for MMF required for the air gap of an armature with slots and ducts. 07
 - b) Calculate the MMF required for air gap of machine having core length = 0.32m, 08
including 4 ducts of 10mm wide , pole area = 0.19m, slot pitch=65.4mm , slot opening = 5mm, air gap length = 5mm, flux per pole 52 mwb, given carter's coefficient for slot =1 and carter's coefficient for duct= 2
- Q.3
- a) Derive the output equation of 3phase induction motor. 07
 - b) Find the main dimension , no of stator turns and stator slots of 5HP , 3 phase , 50Hz, 08
1470 rpm, squirrel cage delta connected motor.
Use the following data
- $$B_{av} = 0.46 \text{ wb/m}^2,$$
- $$ac = 22000 \text{ A/M (Amper conductor)}$$
- Efficiency=83%
Power factor = 0.84 lagging
- Q.4
- a) Discuss the factors determining the choice of rotor slots in induction motor. 07
 - b) Find the current in the rotor bar and end ring of cage rotor of 6 poles, 3 phase induction 08
motor having 72 stator slots with 15 conductors in each slot. The current per phase is 20A and rotor slots are 55Nos.

- Q.5 Attempt any three 15
- Cogging and crawling induction motor.
 - Choice of air gap length in 3 – phase induction motor.
 - Specification and standardization
 - Calculation of AT in tapered tooth
 - Design of heating element

Section – B

- Q.6 Solve any five 10
- Define window space factor in Transformer.
 - Why stepped cores are preferred in the design of transformer.
 - Give two comparisons of distribution and power transformer
 - Enlist different types of winding provided in transformer
 - How heat dissipated in transformer
 - Give two advantages of stepped core in transformer.

- Q.7 a) What is the significance of constant 'K' in transformer? Show that $E_t = \sqrt{Q}$ 07
- b) A 250 KVA, 200V/400V, 50Hz, single phase core type transformer with following data 08
- $E_t = 15V, B_{max} = 1.25 \text{ wb/m}^2$
- current density $\delta = 2.75 \text{ A/mm}^2$, window space factor $= 0.3 \frac{H_w}{W_w} = 3$, Determine the main dimensions and core and Yoke

- Q.8 a) Explain in detail the steps for determination of main dimension for core, window and yoke. 07
- b) A – 3 phase, 50Hz oil cooled core type transformer has the following dimensions 08
- Distance bet'n the core centres = 0.2m
- Height of window = 0.24m
- Diameter of circum scribing circle = 0.34m
- Flux density in the core is 1.25 wb/m^2 and current density in the conductor is 2.5 A/mm^2
- estimate KVA Rating. Assume a window space factor of 0.2 and core area factor is 0.56
- the core is two stepped.

- Q.9 a) Explain in detail various cooling methods provided for cooling of different types of transformer. 07
- b) Derive the expression for calculation of total no. of cooling tubes provided on transformer tank. 08

Q.10 Attempt any three

15

- a) Window space factor and its significance in transformer.
- b) Types of mechanical forces developed under short circuit condition in transformer
- c) Obtain the expression for leakage reactance of 3 phase core type transformer.
- d) Estimation of no load current in single phase transformer.

Total No. of Printed Pages:2

SUBJECT CODE NO:- H-127
FACULTY OF SCIENCE AND TECHNOLOGY
T.E. (EEP/EE/EEE) (Sem-II)
Power Electronics
[OLD]

[Time: Three Hours]

[Max. Marks:80]

Please check whether you have got the right question paper.

N.B.:

- i) Q.No.1 and Q.No.6 are compulsory.
- ii) Solve any two questions from remaining in each section.
- iii) Assume suitable data if required.
- iv) Draw appropriate waveforms if required.

SECTION – A

- | | | |
|-----|--|----------|
| Q.1 | Solve any five from following. | 10 |
| | <ol style="list-style-type: none"> a) Draw U-I characteristics of TRIAC. b) Give the comparison between GTO and SCR. c) What is power electronic? Justify it. d) What are the different between fully controlled and half controlled Rectifiers? e) What are the different classification of chopper? f) What are the advantage of free wheeling diode in controlled rectifier? g) List the advantage of MOSFET. h) Give any two power ratings of any two power devices. | |
| Q.2 | <ol style="list-style-type: none"> a) What is free wheeling diode? What are its function? b) Explain with neat circuit the triggering Requirement of IGBT. | 07
08 |
| Q.3 | <ol style="list-style-type: none"> a) Explain the operation of 3-ϕ half controlled converter with RL Load. b) A-3-ϕ half wave controlled rectifier supplying a constant load current of 30A, operated from three phase 400V (Line) Supply. Find the average load voltage at firing angle 45°. What value of current and peak reverse voltage rating will the thyristor require. | 07
08 |
| Q.4 | <ol style="list-style-type: none"> a) What is dual converter? Explain the basic principle of operation of ideal dual converter. b) Draw and Explain the dynamic turn on and off characteristics of SCR. | 07
08 |
| Q.5 | <ol style="list-style-type: none"> a) Explain working of 3-ϕ fully controlled bridge Rectifier. b) Explain principle of operation of Time ratio control and current limit control strategies for chopper circuit. | 07
08 |

SECTION – B

- | | | |
|-----|---|----|
| Q.6 | Answer any five Questions. | 10 |
| | <ol style="list-style-type: none"> a) Define modulation index of PWM inverter. b) What is duty cycle? c) What are the effects of chopping frequency on filter sizes? | |

- d) What is UPS and power conditioners?
- e) What is switching mode power supplies?
- f) Why thyristors are not preferred for inverters?
- g) What is SMPs?
- h) What are the specifications of power supplies used in industrial application?

- Q.7 a) Prove that the average output voltage of Step up chopper is given by $V_o = \frac{V_{ac}}{1-\alpha}$ Where V_{ac} =Supply (dc) voltage $-\alpha$ duty ratio 07
- b) A chopper circuit supplied from 80V dc battery, supplies a R-L Load with $L=40$ mH and $R=6\Omega$. The load has freewheeling diode across it. It is required to vary to load current between 10A and 12A. Calculate the time ratio of chopper. 08
- Q.8 a) Explain working principle of single phase AC voltage controller. 07
- b) An AC voltage controller has a Resistive load of 10 ohms and RMS input voltage is $V_s=230V$, 50 Hz. The SCR are switched on for $n=25$ cycles and off for $m=75$ cycles. Determine. 08
- 1) RMS output voltage
 - 2) input power
 - 3) Average and RMS current rating of SCR.
- Q.9 a) Write short notes: 07
- a) Three phase to single phase cycloconverter. 08
 - b) Power conditioners.
- Q.10 a) List out the application of PWM diode converters. 07
- b) Prove that the peak to peak ripple current for Buck –converter is given by $\Delta I = \frac{USK(i-K)}{fL}$ 08

Total No. of Printed Pages:2

SUBJECT CODE NO:- H-162
FACULTY OF SCIENCE AND TECHNOLOGY
TE (EEP / EE / EEE) (Sem-II)
Testing & Maintenance of Electrical Equipment
[OLD]

[Time: Three Hours]

[Max.Marks:80]

Please check whether you have got the right question paper.

- N.B
1. Q.no.1 and Q.no.6 are compulsory
 2. Solve three questions from each section (i.e 2 questions from remaining in each section)
 3. Assume necessary data.

Section -A

- Q.1 Solve any five questions 10
- 1) Define the terms Testing and Maintenance.
 - 2) Give any two examples for special tests carried out on electrical machines.
 - 3) Explain the concept of tolerance with suitable example.
 - 4) What are the objectives of testing?
 - 5) What is the effect of presence of contaminating agents inside transformer 0:1?
 - 6) Mention different type of faults which occur in transformer.
 - 7) What are the different types of maintenance?
- Q.2 a) What are the different methods of testing? Make a comparison between them. 08
b) List out the probable faults in manufacturing of transformer. 07
- Q.3 a) State and explain any test (special test) carried out on transformer. 07
b) Explain with neat sketch regenerative method of testing carried out on rotating machines. 08
- Q.4 a) With the neat sketch explain the test carried out to find out the breakdown strength of transformer oil. 08
b) Explain the brake test carried out on DC machine and also write its importance. 07
- Q.5 Write short notes on any three 15
- i) Magnetic in – balance in 3 – ph transformer
 - ii) Magnetic in – balance in 3 – ph motor
 - iii) Excessive vibration in 3 – ph motor
 - iv) Excessive vibration in 3 – ph transformer

Section – B

- Q.6 Attempt any five questions. 10
- 1) What are the possible reasons if the motor is getting overheated?
 - 2) What are the effects of bent rotor shaft of an induction motor?
 - 3) What are the possible reasons for excessive vibrations in transformer?
 - 4) What is the significance of ultra-sonic testing?
 - 5) What is the effect of use of wrong duty cycle of motor used in industry?
 - 6) Which equipment is used to locate the blow holes present on machine's body?
 - 7) A motor is not supplying the power with full load capacity state the reasons.
- Q.7 a) With the neat sketch explain the heat throw testing on motor. 08
 b) With the proper sketches explain the procedure of D.G.A analysis giving its significance. 07
- Q.8 a) Explain the working of vibration measuring machine (E.M swinging) 08
 b) Enlist the reasons why there is a winding failure usually in HV side of a transformer and name the instrument / test to identify. 07
- Q.9 a) Draw the block diagram indicating working of industrial sonography and explain working of each block. 08
 b) What do you mean by duty cycle? What are the parameters deciding the duty cycle? 07
- Q.10 Write short note on any three 15
- i) Detection of internal cracks
 - ii) Acidity test
 - iii) Dynamic balancing of induction motor
 - iv) High voltage with stand test on machines

Total No. of Printed Pages:2

SUBJECT CODE NO:- H-197
FACULTY OF SCIENCE AND TECHNOLOGY
T.E. (EEP/EE/EEE) (Sem-II)
Microcontrollers & Applications
[OLD]

[Time: Three Hours]

[Max.Marks:80]

Please check whether you have got the right question paper.

N.B

1. Solve any three questions from each section
2. Q.1 & Q.6 are compulsory.
3. Assume suitable data if necessary

Section A

- | | | |
|-----|--|---------------------|
| Q.1 | Solve | 10 |
| | <ol style="list-style-type: none"> a) Explain how the stack is implemented. b) What is the function of data pointer register? c) What is the pipelining of 8086? d) What is Opcode & operand of an instruction e) How the bit addressing is distinguished from byte addressing. | |
| Q.2 | <ol style="list-style-type: none"> a) Explain in detail generation of 20-bit physical address of 8086 microprocessor. b) Explain the different addressing modes of 8086 microprocessor. | <p>08</p> <p>07</p> |
| Q.3 | <ol style="list-style-type: none"> a) What is the last instruction in interrupt service routine? How does it work? b) Write ALP to add ten bytes in internal RAM locations. Assume that number are stored starting from location 20H. Store the reject.(8-bit) at 30H . | <p>08</p> <p>07</p> |
| Q.4 | <ol style="list-style-type: none"> a) Explain in detail TCON special function Register of 8051. b) Explain the PSW of 8051 microcontroller. | <p>08</p> <p>07</p> |
| Q.5 | Write a short note on | 15 |
| | <ol style="list-style-type: none"> a) Flag register in 8086 b) Subroutines c) Bit manipulation instruction of 8051 | |

Section – B

- Q.6 Solve 10
- Elaborate the pin function of port 'O'
 - Differentiate between vectored & non vectored interrupt.
 - Explain how to mark interrupts?
 - What is the priority of interrupt?
 - Explain the function of $\overline{INT0}$ & $\overline{INT1}$ & microcontroller 8051.
- Q.7 a) Write a program to toggle. LED's at port 1. 08
- b) Interface DC motor to 8051 & write a program in ALP to rotate DC motor for given speed. 07
- Q.8 a) Draw a functional block –diagram of time /counter section of 8051. Also explain function of corresponding SFRs. 08
- b) Explain interrupt services provided by 8051 microcontroller. 07
- Q.9 a) Interface seven –segment LED to 8051 write a program to display 0-9 continuously. 08
- b) Explain in detail serial data transection mode O of 8051 microcontroller. 07
- Q.10 Write a short notes on 15
- Interfacing & stepper motor
 - Keyboard interfacing
 - Generation of square waveform using DAC.

Total No. of Printed Pages:2

SUBJECT CODE NO:- H-297
FACULTY OF SCIENCE AND TECHNOLOGY
T.E. (EEP/EE/EEE) (Sem-I)
Special Purpose Electrical Machines
[OLD]

[Time: Three Hours]

[Max.Marks:80]

Please check whether you have got the right question paper.

N.B

1. Q.1 and 6 are compulsory.
2. Solve any two questions from each section.

Section A

- | | | |
|-----|--|----|
| Q.1 | Attempt any five: | 10 |
| | <ol style="list-style-type: none"> a) Why the induction generator is often called as an asynchronous generator? b) Write any four application of stepper motor. c) Why stepper motor called so? d) What is the maximum rating of FHP motor? e) What is the electronic commutator? f) Write applications of synchronous reluctance motor. | |
| Q.2 | a) Explain application of induction generator for mini/micro hydel system. | 07 |
| | b) Explain construction and working of switched reluctance motor. | 08 |
| Q.3 | a) Explain the construction and working of synchronous reluctance motor. | 07 |
| | b) Explain the construction, working and application of PMSM. | 08 |
| Q.4 | a) Describe linear induction motor in detail. | 07 |
| | b) Explain variable reluctance stepper motor in detail. | 08 |
| Q.5 | Write short note on following: | 15 |
| | <ol style="list-style-type: none"> a) Brushless dc motor. b) Self-excitation requirement in case of induction generator . c) Fractional Horse power synchronous motor. | |

Section – B

- Q.6 Solve any five: 10
- Write two applications of high frequency transformer.
 - What are the various reasons of heating-element failure?
 - Give the classification of electric welding.
 - List out types of welding equipment's.
 - State faraday's first law of electrolysis.
 - Define electro plating.
- Q.7
- Explain welding transformer in detail. 07
 - Describe the buck – boost transformer with neat connection diagram. 08
- Q.8
- What is dielectric heating? Explain the factors on which dielectric loss in dielectric material depend. 07
 - Explain MI4 welding in detail. 08
- Q.9
- State and explain laws of electrolysis. 07
 - Describe in detail, the application of electrolytic process used for metal extraction. 08
- Q.10 Write short note on following: 15
- High frequency transformer
 - Induction heating
 - Applications of electrolysis

Total No. of Printed Pages:03

SUBJECT CODE NO:- H-353
FACULTY OF SCIENCE AND TECHNOLOGY
TE(EEP/EE/EEE) (Sem-I)
Control System Engineering
[OLD]

[Time: Three Hours]

[Max. Marks:80]

Please check whether you have got the right question paper.

- N.B.:1) Q. No. 1 and Q. No. 6 are compulsory.
 2) Solve any two from remaining questions from Section A and Section B.
 3) Use suitable data if necessary.

Section - A

Q.1 Solve any five:- 10

- 1) What is time variant and time invariant?
- 2) Define Non-Touching Loop and Loop gain.
- 3) State Mason's Gain Formula.
- 4) What are two types of mechanical system?
- 5) Define the term settling time and Damping ratio.
- 6) What is velocity error coefficient?

Q.2 a) Write the differential equation governing the mechanical rotational system shown in fig (1) and determine the transfer function $\frac{Q(S)}{T(S)}$. 08

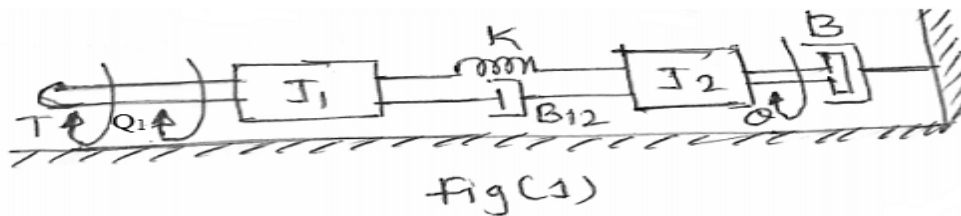

b) Explain open loop and closed loop control system with example. 07

Q.3 a) Find overall gain $\frac{C(S)}{R(S)}$ for the signal flow graph shown in fig (2). 08

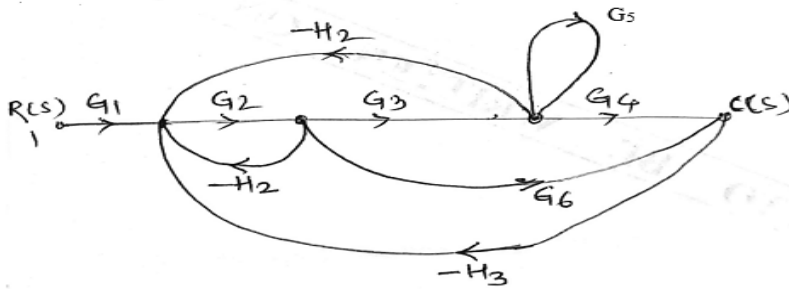

Fig (2).

b) Reduce the block diagram shown in fig (3) and find C/R.

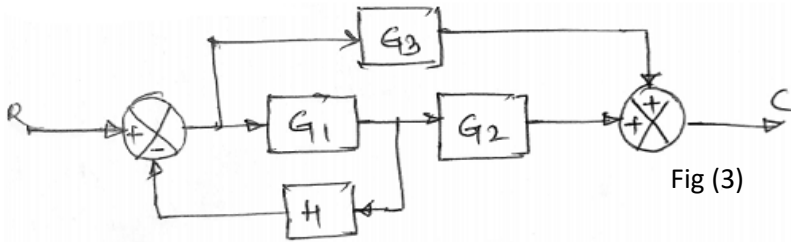

Fig (3)

- Q.4 a) Explain Time domain specification in detail. 08
 b) Derive the expression for first order system for a unit step input. 07

- Q.5 a) Explain steady state and static error constant. 07
 b) The feedback system has open loop transfer function. 08

$G(S).H(S) = \frac{K.e^{-s}}{s(S^2+5S+9)}$ determine by use of the Routh's criterion, the maximum value of 'K' for the closed loop system to be stable.

Section B

- Q.6 Answer any FIVE. 10

- How to calculate angle of departure and angle of Arrival.
- What is centroid? How to calculate centroid?
- What is Bode plot?
- Define PID controller.
- Define the term state space and state variable.
- What do you mean by controllability and observability?

Q.7 Sketch Root locus for the unity feedback system whose open loop transfer function is 15

$$G(S) = \frac{K}{S(S + 4)(S^2 + 4S + 20)}$$

Q.8 For the following transfer function draw bode plot and obtain gain cross over frequency. 15

$$G(S) = \frac{20}{s'(1 + 3S)(1 + 4S)}$$

Q.9 a) Construct a state model for a system described by the differential equation. 08

$$\frac{d^3y}{dt^3} + 6 \frac{d^2y}{dt^2} + 11 \frac{dy}{dt} + 6y + u = 0$$

Give the block diagram representation of the state variable.

b) Determine the state transition matrix for the system. 07

$$\begin{bmatrix} \dot{X}_1 \\ \dot{X}_2 \end{bmatrix} = \begin{bmatrix} -2 & 0 \\ 1 & -1 \end{bmatrix} \begin{bmatrix} X_1 \\ X_2 \end{bmatrix} + \begin{bmatrix} 0 \\ 1 \end{bmatrix} u$$

where $u > 0$

Q.10 a) Explain the effect of addition of poles and zeros on root locus. 07

b) Test the observability of the system described by 08

$$\begin{bmatrix} \dot{x}_1 \\ \dot{x}_2 \end{bmatrix} = \begin{bmatrix} 1 & 1 \\ -3 & -2 \end{bmatrix} \begin{bmatrix} x_1 \\ x_2 \end{bmatrix} + \begin{bmatrix} 0 \\ 1 \end{bmatrix} u$$

$$y = \begin{bmatrix} 1 & 0 \end{bmatrix} \begin{bmatrix} X_1 \\ X_2 \end{bmatrix}$$

Total No. of Printed Pages:02

SUBJECT CODE NO:- H-387
FACULTY OF SCIENCE AND TECHNOLOGY
TE(EEP/EE/EEE) (Sem-I)
Microprocessor & Interfacing
[OLD]

[Time: Three Hours]

[Max. Marks:80]

Please check whether you have got the right question paper.

- N.B.:1) Q. No. 1 & Q. No. 6 are compulsory.
 2) Solve any two questions from the remaining question for each Section.
 3) Assume suitable data & addresses if necessary.

Q.1	Attempt any five questions.	10
	a) Why the data bus is bidirectional? b) What is need of ALE signal in 8085. c) Define Instruction cycle. d) What is CALL instruction. e) What happen when SHLD instruction executed. f) What is difference in SUBB & CMPB instructions?	
Q.2	a) Explain the features of 8085 microprocessor. b) Explain different control signals of 8085 microprocessor.	08 07
Q.3	a) Explain different addressing modes of 8085. b) Draw & explain the timing diagram of memory read cycle.	08 07
Q.4	a) Write a program to find smaller number from a group of ten numbers & Handrunit. b) Explain in detail interrupt structure of 8085.	08 07
Q.5	Write short notes on (any three) <ul style="list-style-type: none"> i) Concept of looping ii) SIM & RIM instruction of 8085 iii) Flag register of 8085 iv) PIN diagram of 8085 microprocessor. 	15

Section B

Q.6	Solve any five questions:-	10
	a) What is function of ADC & DAC. b) Draw PIN diagram of 8255 c) Enlist different regists of 8259.	

- d) What is memory mapped I/O mode.
- e) Write the control word format in the BSR mode.
- f) Write an Instruction to enable all the interrupts in the 8085 system.

- Q.7 a) Explain 8259 PIC in detail. 08
 b) Explain block diagram of 8253 PIT. 07
- Q.8 a) Draw block diagram of 8253 and setup it as square wave generator with +Msecperiod if 08
 input frequency + MH₂.
 b) Draw the interfacing diagram to interface 8 LED'S to 8085 through Port A & Port B of 07
 8255 & write ALP such that when PA LED'S are ON PB LED's are OFF and
 viceversa.
- Q.9 a) Draw the interfacing diagram of stepper motor with 8085 using 8255. Write an ALP to 08
 rotate it in anticlockwise direction. Assume delay subroutine is available at "Delay"
 b) Enlist different modes of 8253 and Explain any one 07
- Q.10 Write short notes on (any three) 15
- a) Specifications of ADC & DAC
 - b) 8251 USART
 - c) DC motor speed control
 - d) 8251 based protective relays

Total No. of Printed Pages:3

SUBJECT CODE NO:- H-422
FACULTY OF SCIENCE AND TECHNOLOGY
T.E. (EEP/EE/EEE) (Sem-I)
Power Systems Analysis
[Old]

[Time: Three Hours]

[Max. Marks:80]

Please check whether you have got the right question paper.

- N.B.:i) Question No.1 and Question No.6 are compulsory.
 ii) Attempt from each section any two questions from remaining questions.
 iii) Assume suitable data wherever necessary.

Section– A

- Q.1 Solve any five question from the following. 10
- What are components of power system.
 - What are advantages of per unit computations.
 - What is bus admittance matrix.
 - Define i) node ii) Link
 - What do you mean by PQ bus?
 - What is need of base value?
 - What is impedance and reactance diagram.
 - A generator rated at 30 MVA, 11KV has a reactance of 20%. Calculate its p.u. reactance for a base of 50 MVA and 10 KV.
- Q.2 07
- Determine per unit impedance of 1- \emptyset transformer. 08
 - Choosing a common base of 20MVA. Compute the p.u. reactance of the power system shown in fig.1 below and draw the reactance diagram.

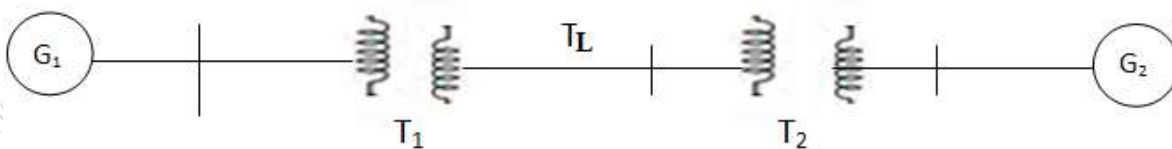

fig-1

- G_1 : 20 MVA, 10.5KV, $X'' = 1.4\Omega$
 G_2 : 10 MVA, 6.6 KV, $X'' = 1.2 \Omega$
 T_1 :10 MVA, 33/11 KV, $X=15.2$ ohms per phase on H.T side.
 T_2 :10 MVA, 33/6.2 KV, $X = 16.0\Omega$ per phase on HT side.
 $T_L=22.5$ ohms per phase.

- Q.3 07
- Determine the primitive network equation. 08
 - For the power system shown in fig.2. Find A, \bar{A} and B.

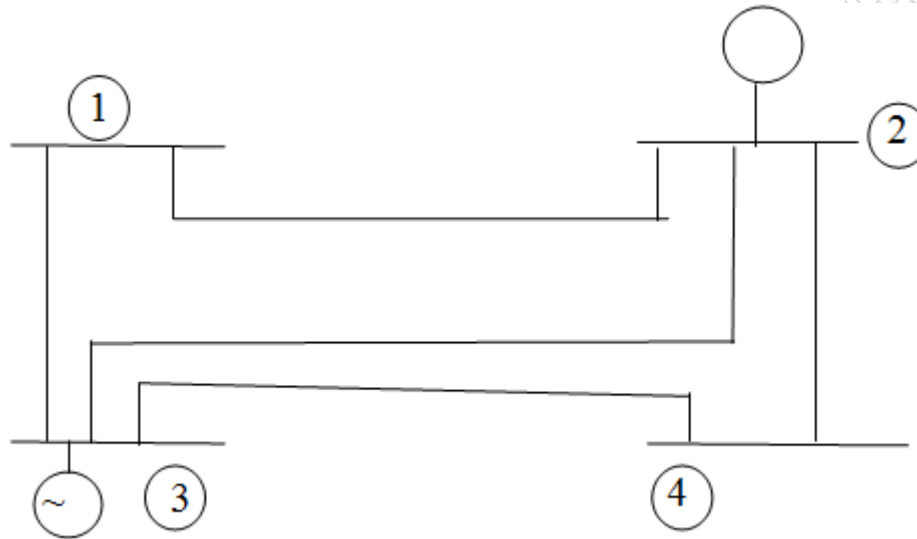
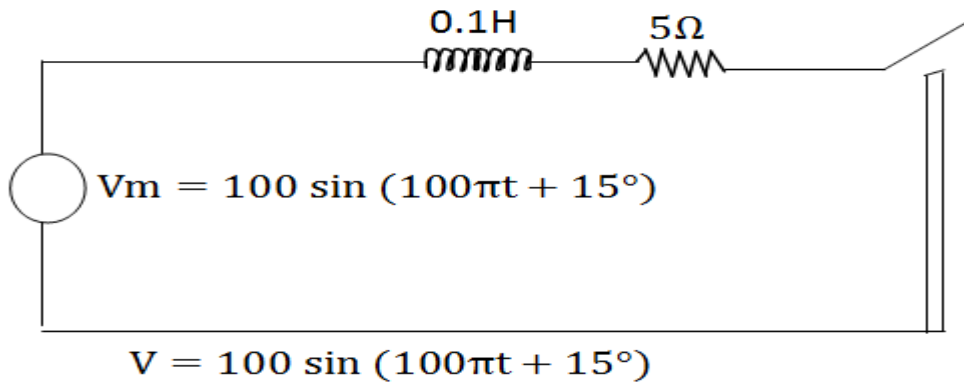

Fig-2

- Q.4 a) Explain fast decoupled method algorithm for load flow study. 07
 b) Derive an Expression for symmetrical components of current $I_s = A^{-1}I_p$. 08
- Q.5 a) Explain the selection of circuit breakers. 07
 b) Derive the expression for transients on transmission line. 08

Section – B

- Q.6 Solve any five questions of the following. 10
- Define maximum momentary current.
 - How the faults are classified?
 - What is meant by doubling networks?
 - What is the significance of sub transient reactance in short circuit studies?
 - What is difference between L-L and L-L-G fault?
 - How symmetrical faults are analyzed?
 - What is the need for short circuit studies?
 - What are sequence impedance and the sequence Network?
- Q.7 a) Explain the sequence impedance and network of synchronous machine. 07
- Positive – sequence impedance and network.
 - Negative sequence impedance and network.
- b) A transmission line of inductance 0.1H and resistance 5Ω is suddenly short circuited at $t=0$ at the bar end as shown in figure below. Find approximately the value of the first current maximum. 08



- Q.8 a) Explain Z Bus building for type 2 and type-3 modifications. 07
 b) Determine the symmetrical components of the three currents.
 $I_a = 10\angle 0^\circ A$, $I_b = 10\angle 230^\circ L$ and $I_c = 10\angle 130^\circ A$ 08
- Q.9 a) Derive an Expression to determine fault current for line to line fault and draw the sequence network. 07
 b) A 3- ϕ 11KV, 20 MVA generators with positive negative and zero sequence reactance as 0.4 p.u, 0.4 p.u. and 0.1 p.u. respectively, is grounded through a reactance of 0.6 Ω . Calculate the fault current for a single line to ground fault. 08
- Q.10 a) Explain the open conductor faults. 07
 b) Explain briefly the static security analysis at control centers. 08

Total No. of Printed Pages:3

SUBJECT CODE NO:- H-524
FACULTY OF SCIENCE AND TECHNOLOGY
T.E.(EEP/EE/EEE) (CGPA) (Sem-I)
Power System Analysis
(Revised)

[Time: Three Hours]

[Max.Marks:80]

Please check whether you have got the right question paper.

N.B

1. Questions no.1 and question no.6 are compulsory
2. Attempt any two questions from the remaining questions of each section.
3. Assume suitable data wherever necessary.

Section A

- Q.1 Solve any five questions of the following 10
- 1) Define per unit value.
 - 2) A generator rated at 30 MVA, 11kv has a reactance of 20% calculate its P.U reactance for a base of 50 MVA and 10KV.
 - 3) What is bus?
 - 4) What is need of slack bus?
 - 5) What is need of base values?
 - 6) Define voltage controlled bus.
 - 7) What are different types of load buses?
- Q.2 a) Derive the expression for per unit impedance referred to base value. 07
- b) Draw the per unit reactance diagram for power system shown in figure below. Neglect the resistance and use a base of 100 MVA, 220 KV in a 50 Ω line. The rating of generator motor and transformers are as follows. 08
- $G: 40\text{ MVA}, 25\text{KV}, X^{11} = 20\%$
 $M: 50\text{ MVA}, 11\text{KV}, X^{11} = 30\%$
 $T_1: 40\text{ MVA}, 33/220\text{ KV}, X = 15\%$
 $T_2: 30\text{MVA}, 11/220\text{KV KV}, X = 15\%$
 Load :11KV, 50MW+ j 68 MVAR.

Determine the new per unit value of reactance of transmission line, and new values of per unit reactance of T_1 , generator G, transformer T_2 and motor M.

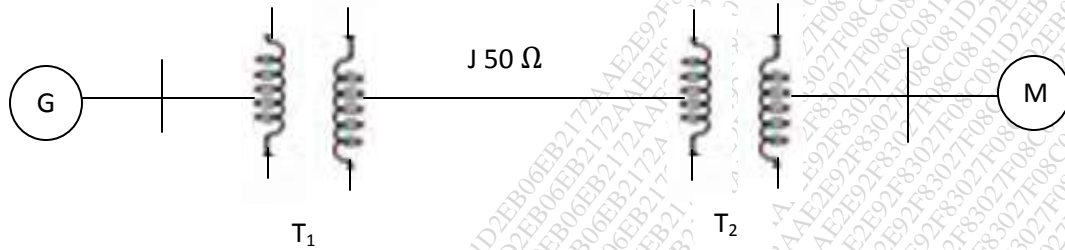

Fig. 1

- Q.3 a) Derive the expression for primitive net work 07
 b) For the power system as shown in fig.2 obtain the B , \bar{B} and K . Take ground as Reference 08

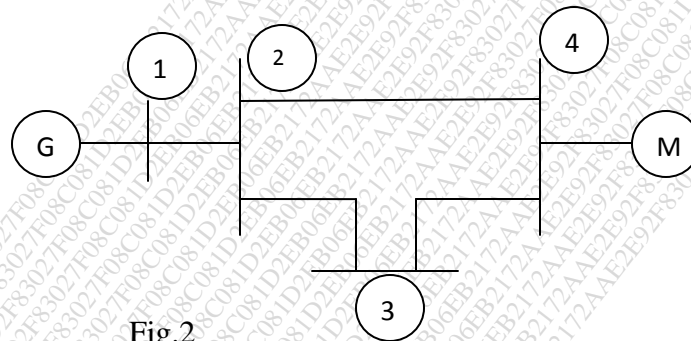

Fig.2

- Q.4 a) Explain the step by step procedure for NR method of load flow studies. 07
 b) Find the bus impedance matrix for the system whose reactance diagram is shown figure 08
 .3 below all the impedance are P.V

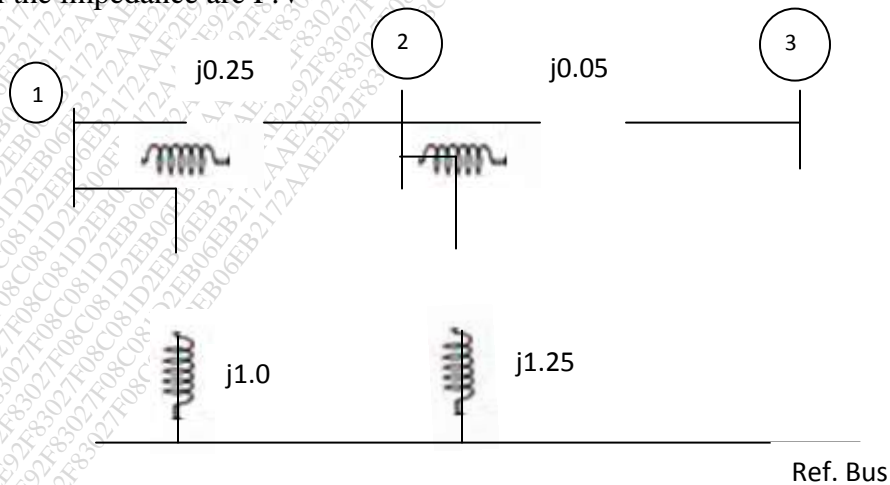

Fig.3

- Q.5 a) Derive an expression for symmetrical components of $V_s = A_{V_P}^{-1}$ 07
 b) Derive the Expression for transients on transmission line. 08

Section – B

- Q.6 Solve any five questions of following 10
 a) What is meant by fault?
 b) Define sub transient reactance.
 c) What is meant by doubling effect?
 d) What is the sequence operator?
 e) What is synchronous reactance?
 f) Give the classification of fault occurs on system.
 g) What is the reason for transients during short circuit?
 h) List the various shunt and series faults.

- Q.7 a) Explain the sequence impedance and network of synchronous machine. 07
 b) Determine the symmetrical components of three voltages. 08

$$V_a = 200 \angle 0^\circ, V_b = 200 \angle 245^\circ \text{ and } V_c = 200 \angle 105^\circ$$

- Q.8 a) Explain Z_{Bus} Building for Type 3 and Type 4 modification. 07
 b) A 25 MVA, 11KV generator has $X_d = 0.2 \text{ P.V.}$ it is negative and zero sequence reactance are respectively 0.3 and 0.1 P.V. the neutral of generator is solidly grounded determine the fault current in the generator and line voltage for L-G fault condition. 08

- Q.9 a) Derive the expression to determine fault current for L-L fault and draw sequence network. 07
 b) Draw positive, negative and zero sequence impedance diagram for figure below 08

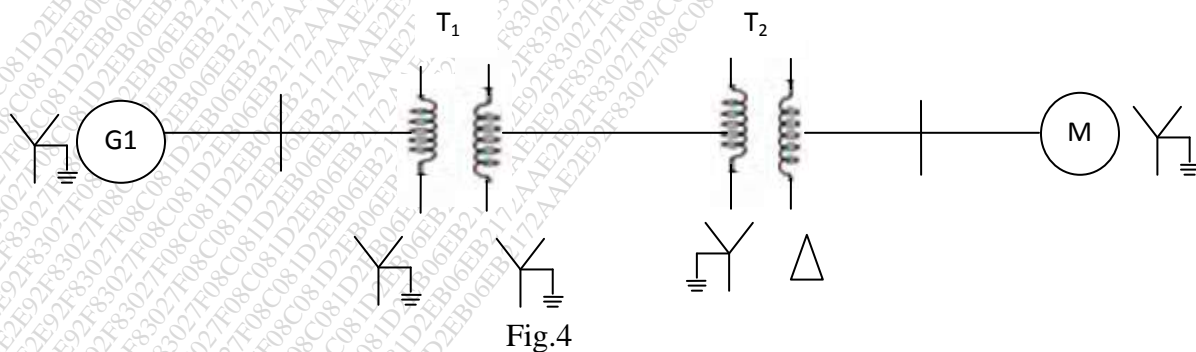

Fig.4

- Q.10 a) Explain open conductor fault. 07
 b) Explain contingency selection and static security analysis. 08

Total No. of Printed Pages:02

SUBJECT CODE NO:- H-531
FACULTY OF SCIENCE AND TECHNOLOGY
T.E.(EEP/EE/EEE) (CGPA) (Sem-I)
Microprocessors And Interfacing
(Revised)

[Time: Three Hours]

[Max.Marks:80]

Please check whether you have got the right question paper.

N.B

- 1) Q. No. 1 and Q.No.6 are compulsory.
- 2) Attempt any two questions from the remaining questions in each section.
- 3) Assume suitable data & address if necessary.

Section A

- Q.1 Solve any five questions:- 10
- a) Define opcode and operand.
 - b) What is the function of accumulator?
 - c) Why program counter & stack pointer are 16-bit registers?
 - d) What is the function of instruction register?
 - e) Why multiplexing is done in 8085?
 - f) What is flag register?
 - g) Give the difference between JZ & JNZ.
 - h) Define i) T-state ii) Machine cycle
- Q.2 a) What are the terminologies used in microprocessor? Explain in detail. 07
- b) With neat block diagram. Explain the different memory units in microprocessor. 08
- Q.3 a) Explain addressing modes of 8085. 07
- b) Draw and explain the flag register in brief. 08
- Q.4 a) What are the features of 8085? 05
- b) With neat diagram explain the pin diagram of 8085 in detail. 10
- Q.5 a) Write a program to sort given 10 numbers from memory location 2200H in the ascending order. 07
- b) Explain CALL & RET instructions in detail. 08

Section B

- Q.6 Solve any five questions:- 10
- a) Mention the purpose of SID & SOD.
 - b) What is ADC & DAC?

- c) What are the modes of operations used in 8253?
- d) What is USRAT?
- e) What are features of 8255?
- f) Write the control signals used in 8255 PPI.
- g) Enlist different registers of 8259.

- Q.7 a) Explain block diagram of 8259 in detail with neat diagram. 07
- b) Draw the interfacing diagram of stepper motor and write ALP to rotate through 90° clock wise direction. 08
- Q.8 a) Explain the block diagram of 8257 in detail. 07
- b) Write a program to generate a time delay 5m sec. Using 8253. Assume clock frequency 08 1MHZ.
- Q.9 a) Explain the block diagram of 8251 USART in detail with neat diagram. 07
- b) Draw the interfacing diagram to interface LED's to 8085 through Port-A & port -B of 08 8255. Write a ALP to operate Port A & Port B LED's are ON & OFF simultaneously.
- Q.10 Write a short note on:- 15
- a) ADC 0809 & DAC 0808 interface
 - b) 8253 modes of operation
 - c) 8279 keyboard/ display interface.

Total No. of Printed Pages:02

SUBJECT CODE NO:- H-538
FACULTY OF SCIENCE AND TECHNOLOGY
T.E.(EEP/EE/EEE) (CGPA) (Sem-I)
Electromagnetic Fields
(Revised)

[Time: Three Hours]

[Max.Marks:80]

Please check whether you have got the right question paper.

- N.B
- i. Que. No. 01 & Que no. 06 are compulsory.
 - ii. Attempt any two questions from remaining questions of each section.
 - iii. Assume suitable data wherever necessary.

Section A

- Q.1 Attempt any five 10
- a) Given two points A (2, -5, -4) & B (3,5,2) find distance of A from B.
 - b) State divergence theorem.
 - c) Define electric dipole & dipole moment.
 - d) Define potential gradient.
 - e) Given two vector $\vec{A} = 2\hat{a}_x + 2\hat{a}_y$ & $\vec{B} = 3\hat{a}_x + 4\hat{a}_y - 2\hat{a}_z$, then find $(\vec{A} \times \vec{B})$
 - f) Define current & current density.
 - g) Define Del Operator.
- Q.2 07
- a) Show that $\vec{A} = 6\hat{a}_x - 2\hat{a}_y + \hat{a}_z$ & $\vec{B} = \hat{a}_x + 6\hat{a}_y + 6\hat{a}_z$ are perpendicular to the each other. 08
 - b) Derive the expression for electric field intensity due to infinite sheet of charge located in $z = 0$ or (xy plane).
- Q.3 07
- a) Given $\vec{A} = 30. e^{-r} \hat{a}_r - 2z \hat{a}_z$ in cylindrical coordinate system. Evaluate both sides of divergence theorem for volume endured by $r = 2$, $z = 0$ & $z = 5$. 08
 - b) State & explain Maxwell's first equation applied to electrostatics or point form of Gauss law.
- Q.4 07
- a) Drive the expressions for boundary condition between two perfect dielectrics. 08
 - b) In cylindrical coordinate system $\vec{J} = (10. e^{-100r})\hat{a}_\phi$ A/m². Find the current crossing through the region of $0.01 \leq r \leq 0.02m$, $0 \leq Z \leq 1$ m & intersection of this region with $\phi = \text{constant}$ plane.
- Q.5 07
- a) Derive the expression for potential due to a point charge. 08
 - b) A point charge $Q = 0.4$ nc is located at the origin. Obtain the absolute potential at point A (2, 2, 3).

Section B

- Q.6 Attempt any five 10
- a) Define magnetic flux
 - b) Define capacitance
 - c) State stokes theorem.
 - d) Define scalar magnetic potential.
 - e) Define Lorentz force
 - f) State faradays law
 - g) Define permeability
- Q.7 a) State & explain Ampere circuital law. 07
- b) Evaluate both sides of stokes theorem for the field $\vec{H} = 6xy \hat{a}_x - 3y^2 \hat{a}_y$ A/m & the rectangular path around the region, $2 \leq x \leq 5, -1 \leq y \leq 1$ & $z = 0$. Let the positive direction of \vec{ds} be \hat{a}_z . 08
- Q.8 a) Derive the expressions of boundary conditions between two different magnetic materials. 07
- b) Derive the expression for magnetic field intensity in free space due to infinite long straight filament. 08
- Q.9 a) Derive the expression for force on a differential current element. 07
- b) Compare the magnetic & electric circuit with neat diagrams. 08
- Q.10 Write a short note on 15
- a) Magnetic dipole moment
 - b) Self-inductance & Mutual inductance
 - c) Magnetization.

Total No. of Printed Pages:03

SUBJECT CODE NO:- H-545
FACULTY OF SCIENCE AND TECHNOLOGY
T.E.(EEP/EE/EEE) (CGPA) (Sem-I)
Control System Engineering
(Revised)

[Time : Three Hours]

[Max.Marks:80]

Please check whether you have got the right question paper.

N.B

- 1) Q. No. 1 and Q. No. 6 are compulsory.
- 2) Solve any two from remaining questions from each section.
- 3) Use suitable data if necessary.

Section A

- Q.1 Solve any Five questions. 10
- a) What is time variant and time invariant?
 - b) What do you mean by signal flow graph?
 - c) Define Rise time and delay time.
 - d) What does the term 'stability' of a control system imply?
 - e) What is velocity error coefficient?
 - f) What are standard test signals employed for time domain studies?
- Q.2 a) Draw a mechanical network hence write differential equation for the network shown in fig (1) also determine transfer function. 08

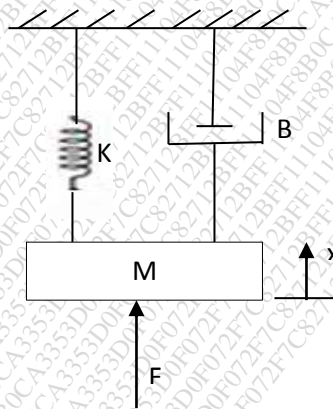

Fig (1)

- b) Explain open loop and closed loop control system with suitable example. 07
- Q.3 a) Explain block reduction technique rule in detail. 07
- b) Find overall gain $\frac{C(S)}{R(S)}$ for the signal flow graph shown in fig (2). 08

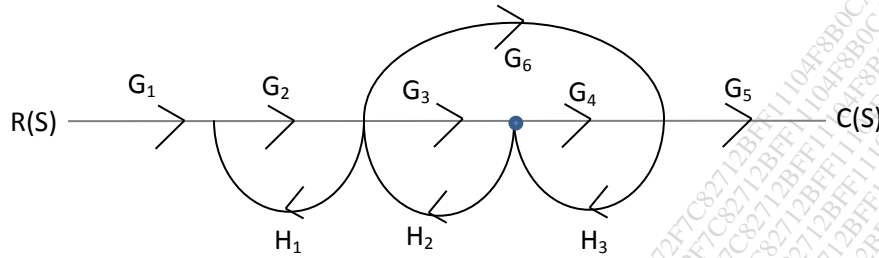

Fig (2)

- Q.4 a) Derive the expression for under damped second order system for unit step input. 08
 b) Explain the parameters of time domain specifications. 07
- Q.5 a) Explain steady state and static error constant. 07
 b) The characteristic equation of feedback controlled system is given by, 08
 $S^4 + 20S^3 + 15S^2 + 2S^1 + K = 0$, determine the range of values of 'K' for the system to be stable.

Section B

- Q.6 Answer any FIVE. 10
 a) What do you mean by Root locus?
 b) What is centroid? How centroid is calculated?
 c) What is bode plot?
 d) Define Gain and phase margin?
 e) Define the term observability and controllability.
 f) What do you mean by PID controller?
- Q.7 The open loop transfer function of a unity feedback system is given by, 15
 $G(S) = \frac{K(S+9)}{S(S^2+4S+11)}$, Sketch the root locus of the system.
- Q.8 For the following transfer function draw bode plot and obtain gain cross-over frequency. 15
 $G(S) = \frac{20}{S(1+3S)(1+4S)}$
- Q.9 a) Construct a state model of a system whose transfer function is given as, 07
 $\frac{y(S)}{u(S)} = \frac{10}{S^3+4S^2+2S+1}$
 b) Determine the state transition matrix for the system, 08
 $\begin{bmatrix} \dot{x}_1 \\ \dot{x}_2 \end{bmatrix} = \begin{bmatrix} -2 & 0 \\ 1 & -1 \end{bmatrix} \begin{bmatrix} x_1 \\ x_2 \end{bmatrix} + \begin{bmatrix} 0 \\ 1 \end{bmatrix} u$ where $u > 0$.

Q.10

- a) Explain controllability and observability of a linear system.
- b) Test for controllability and observability of the system described by.

07

08

$$\begin{bmatrix} \dot{x}_1 \\ \dot{x}_2 \end{bmatrix} = \begin{bmatrix} 1 & 1 \\ -3 & -2 \end{bmatrix} \begin{bmatrix} x_1 \\ x_2 \end{bmatrix} + \begin{bmatrix} 0 \\ 1 \end{bmatrix} u,$$

$$y = [1 \quad 0]$$

Total No. of Printed Pages:02

SUBJECT CODE NO:- H-556
FACULTY OF SCIENCE AND TECHNOLOGY
T.E.(EEP/EE/EEE) (Sem-I)
Elective-II Special Purpose Electrical Machines
(Revised)

[Time : Three Hours]

[Max.Marks:80]

Please check whether you have got the right question paper.

- N.B
- i. Q.1 and Q.6 are compulsory.
 - ii. Attempt any two questions from the remaining questions in each section.
 - iii. Assume suitable data, if necessary.

Section A

- | | | |
|-----|---|----------|
| Q.1 | Solve any five | 10 |
| | <ol style="list-style-type: none"> a) Draw the equivalent circuit of self-excited induction generator. b) What is stepper motor? c) What are the classifications of synchronous reluctance motor? d) What are the disadvantages of switched reluctance motor? e) What are the advantages of brushless dc motor? f) What is meant by "Axial airgap"? | |
| Q.2 | <ol style="list-style-type: none"> a) Explain application of induction generator for mini/micro hydel system. b) Explain the construction and working principle of BLDC motor. | 07
08 |
| Q.3 | <ol style="list-style-type: none"> a) Differentiate between the operation and working of Axial and Radial air gap synchronous reluctance motors with neat sketches. b) Explain the self-excitation requirements in case of induction generator. | 08
07 |
| Q.4 | <ol style="list-style-type: none"> a) Describe the operation of multi stack stepper motor. b) Explain the construction and operation of PMSM motor. | 08
07 |
| Q.5 | Write short note on following. <ol style="list-style-type: none"> a) Comparative study of three type stepper motor. b) Switched reluctance motor. c) Linear induction motor | 15 |

Section B

- | | | |
|-----|--|----|
| Q.6 | Solve any five from following | 10 |
| | <ol style="list-style-type: none"> a) What is buck boost transformer? b) Write the two applications of high frequency transformer. c) What are the various reasons of heating element failure? d) What type of electric supply is suitable for arc welding. e) Define current efficiency in electrolytic process. f) Why arc welding is sometimes called the non – pressure welding. | |

- Q.7 a) Explain isolation transformer in detail with application. 07
 b) Explain with diagram, working of core type induction furnace. 08
- Q.8 a) Explain the different methods of induction heating. Give some application of induction heating. 07
 b) Explain MIG welding in detail. 08
- Q.9 a) Explain in brief the principle of electro deposition? State the factors on which the quality of electro deposition depends. 08
 b) Explain the process extraction of aluminum. 07
- Q.10 Write short note on following 15
 a) High frequency transformer
 b) Dielectric heating
 c) Applications of electrolysis

Total No. of Printed Pages:2

SUBJECT CODE NO:- H-557
FACULTY OF SCIENCE AND TECHNOLOGY
T.E.(EEP/EE/EEE) (CGPA) (Sem-I)
Elective-II Digital Electronics
(Revised)

[Time: Three Hours]

[Max.Marks:80]

- N.B Please check whether you have got the right question paper.
- i) Question no.1 & 6 are compulsory.
 - ii) From the remaining solve any two questions from each section.
 - iii) Figures to the right indicate full marks.

Section A

- | | | |
|-----|---|----------|
| Q.1 | Solve any five questions of the following | 10 |
| | <ol style="list-style-type: none"> a) What is combinational logic? b) What is a truth table? c) What do you mean by Duals? d) State the limitation of K – map. e) Convert $(65.35)_{10}$ to hexadecimal. f) Find 2's complement of the binary number 101100. | |
| Q.2 | <ol style="list-style-type: none"> a) Explain Law's of Boolean Algebra in details. b) State & prove De-morgan's theorems. | 07
08 |
| Q.3 | <ol style="list-style-type: none"> a) Explain in detail Number system used in Digital electronics. b) Explain TTL logic in detail. | 07
08 |
| Q.4 | <ol style="list-style-type: none"> a) Define 32:1 multiplexer using 16:1 multiplexer. b) Show the construction of 4-bit parallel adder using IC 7483 | 08
07 |
| Q.5 | Write short note on [any three]: | 15 |
| | <ol style="list-style-type: none"> a) BCD code b) RTL c) K-map d) Full adder e) ALU | |

Section – B

- | | | |
|-----|--|----|
| Q.6 | Solve any five from the following: | 10 |
| | <ol style="list-style-type: none"> a) Define sequential logic circuits. b) What is mean by synchronous sequential circuits? c) Define synchronous counters. d) What is meant by Master-Slave flip-flop? e) Explain flash memory. f) Define a synchronous sequential circuit. | |

- Q.7 a) Compare the combinational & sequential circuits. 07
 b) With the aid of a neat sketch. Explain the operation of J – K flip flop. 08
- Q.8 a) What is race around condition? How it is avoided? 07
 b) Explain the operation of 4-bit serial in serial out shift register with the help of neat diagram. 08
- Q.9 a) Draw & explain the block diagram of Mealy model. 08
 b) Explain in detail Design of Combinational & sequential circuits. 07
- Q.10 Write short note on [any three]: 15
 a) Classification & characteristics of memory.
 b) PAL.
 c) PLA.
 d) Shift register.

Total No. of Printed Pages:2

SUBJECT CODE NO:- H-558
FACULTY OF SCIENCE AND TECHNOLOGY
T.E.(EEP/EE/EEE) (CGPA) (Sem-I)
Elective-II Communication Engineering
(Revised)

[Time : Three Hours]

[Max.Marks:80]

Please check whether you have got the right question paper.

N.B

1. Questions No.1 & 6 are compulsory.
2. Attempt any 2 questions from each section A & B
3. Assume suitable data wherever necessary.

Section A

- | | | |
|-----|--|----|
| Q.1 | Solve any five questions. | 10 |
| | <ol style="list-style-type: none"> a) Give the importance of OFC. b) Give the applications of AM. c) What is the function of core & cladding in optical fiber? d) What do you mean by multiplexing. e) Give the importance of Digital modulation techniques. f) What is coding & decoding technique? | |
| Q.2 | <ol style="list-style-type: none"> a) Draw a block diagram of fiber optic communication system & describe the function of each component. | 08 |
| | <ol style="list-style-type: none"> b) Differentiate between step index & Graded index fiber? How the rays do propagates in graded index fiber? | 07 |
| Q.3 | <ol style="list-style-type: none"> a) Draw the block diagram of PSK system & explain its working. | 08 |
| | <ol style="list-style-type: none"> b) Explain the OSI reference model. | 07 |
| Q.4 | <ol style="list-style-type: none"> a) Define the term 'Modulation' and explain the concept of amplitude modulation . | 07 |
| | <ol style="list-style-type: none"> b) Explain clearly the difference between phase modulation & frequency modulation. | 08 |
| Q.5 | Write short note on. | 15 |
| | <ol style="list-style-type: none"> a) Sampling theorem b) Pulse modulation c) Broadcast & point to point communication | |

Section – B

- Q.6 Attempt any five 10
- Define Kepler’s second law
 - What is an orbit?
 - What is smart grid communication?
 - What is data communication over power lines?
 - What are the modulation schemes for PLC?
 - What is IP?
- Q.7 a) What are the communication system used in power stations? Explain in detail. 08
- b) Explain laws of planetary motion in detail. 07
- Q.8 a) Explain in detail Remote energy metering protocols. 07
- b) Explain in detail communication in power distribution grid . 08
- Q.9 a) What is WAN? Explain in detail fiber optical networks related to WAN. 08
- b) What is IP? Explain Real time data transmission related to IP. 07
- Q.10 Write short note on 15
- Satellite communication
 - Modulation schemes for PLC
 - Zigbee.

Total No. of Printed Pages:02

SUBJECT CODE NO:- H-569
FACULTY OF SCIENCE AND TECHNOLOGY
T.E.(EEP/EE/EEE) (Sem-II)
Electrical Machine Design
[REV]

[Time: Three Hours]

[Max. Marks: 80]

Please check whether you have got the right question paper.

N.B

- i) Q. No. 1 and Q. No. 6 are compulsory.
- ii) Attempt any two questions from remaining questions from each section.
- iii) Assume suitable data, if required.

SECTION - A

- | | | |
|-----|---|----------|
| Q.1 | Attempt any Five | 10 |
| | <ol style="list-style-type: none"> a) Enlist different design circuits of electrical machines. b) Define specific Magnetic loading c) What do you mean by standardization in design of electrical machines? d) What is the significance of Carter's coefficient? e) Why rotors conductors of squirrel cage rotor are not provided with insulation f) What do you mean by gap contraction factor? | |
| Q.2 | <ol style="list-style-type: none"> a) Derive the expression for MMF required for the air gap of an armature with slots and ducts. b) Calculate the apparent flux density at a particular section of tooth from the following data: Tooth width = 12mm, slot width = 10mm, gross core length = 0.32 m, no of ventilating ducts = 4 with each of 10mm, real flux density = 2.2 Wb/m². Permeability of teeth corresponding to real flux density = 31.4×10^{-6} H/m. stacking factor = 0.9 | 07
08 |
| Q.3 | <ol style="list-style-type: none"> a) State and explain the factors to be considered when estimating the length of air gap of a 3 phase induction motor. b) Find the Main dimensions of 15kw, 3 phase, 400V, 50Hz, 2810rpm, squirrel cage induction motor having an efficiency of 88% and full load Power factor = 0.9, Assume specific Magnetic loading = 0.5T, Specific electric loading = 25000 A/m, The rotor peripheral speed should be approximately 20 m/s at synchronous speed. | 07
08 |
| Q.4 | <ol style="list-style-type: none"> a) Explain in detail design of rotor bars and slots of squirrel cage rotor of 3 phase induction motor. b) Find the current in the bars and endrings of a cage rotor of 6 pole, 3 phase, induction motor having 72 stator slots with 15 conductors in each slot, if the stator current per phase is 20 Amp, and rotor slots are 55. | 07
08 |

- Q.5 Write short note (Attempt any three) 15
- Limitations in the design of electrical machines.
 - Cogging and crawling in induction motor
 - Output equation of 3-phase induction motor
 - Selection of rotor slots in 3-phase induction motor

SECTION – B

- Q.6 Attempt any five 10
- Which winding in transformer placed near to core? Why?
 - Give the advantages of stepped core of transformer.
 - Explain the causes of temperature rise in transformer.
 - Define heating time constant.
 - Why the area of yoke of a transformer is usually kept 15-20% more than that of core.
 - Give two comparisons of distribution and power transformer.
 - Enlist the various cooling method provided for transformer.
- Q.7 07
- Explain in detail the steps for determination of main dimension for core, window and yoke of transformer.
- 08**
- b) Calculate the KVA output of a single phase transformer from the following data.
- Core height / distance between the centres=2.8
 Diameter of circumscribing circle / distance between core centers = 0.56
 Net iron area / Area of circumscribing circle = 0.7
 Current density is 2.3 A/mm², window space factor is 0.27, frequency = 50Hz flux density of core = 1.2 Wb/m², distance between core centers = 0.4 m
- Q.8 07
- Explain in detail the design of square and stepped core of transformer.
- 08**
- b) Calculate approximate overall dimensions for 200 KVA, 6000/400V 3 phase core type transformer. The following data may be assumed:
 Emf per turn = 10V, maximum flux density = 1.3 Wb/m², current density = 2.5A/mm², Window space factor = 0.3, Overall height = Overall width, stacking factor = 0.9, Use a 3 stepped core for which net iron area is 0.6d² and width of largest stamping is 0.9d
- Q.9 08
- Derive the expression for calculation of no. of cooling tubes provided on surface of transformer tank.
- 07**
- b) Explain in detail types of mechanical forces developed in transformer winding.
- Q.10 Attempt any three 15
- Explain function of conservator and breather in transformer
 - Explain selection of winding used for transformer design
 - Explain design of choke
 - Explain choice of window space factor for transformer design.